

CPD15/18/20TVL Counterbalance Lift Truck Parts Manual

平衡重式叉车
零件目录



PARTS ORDERING INSTRUCTIONS

HOW TO ORDER

When you order, supply the part number, quantity, model and serial numbers of your machine. Supplying this information will assure prompt, efficient handing of your order.

Since your dealer carries many parts in stock and maintains up-to-date prices on all parts, he will be able to process your order immediately. If, for some reason, the part is not in stock, he will order it from the factory. In either event, he maintains a current file of service manuals, which give all available parts ordering or technical information.

WHERE TO ORDER

Always order parts from the dealer who sold you your electric forklift . If it is necessary for the dealer to order parts from the factory, he is able to get prompt service for you. Parts are shipped in accordance with shipping instructions given on the order.

INSTRUCTIONS FOR RETURNING PARTS

Under NO CIRCUMSTANCES will parts be accepted at the factory for credit without prior approval . We cannot accept responsibility for parts returned without authorization.

If you have some parts which must be returned, contact your dealer. If he believes parts should be returned, he will arrange for authorization to return the parts.

CHANGES

When changes are made to the machine, revised pages for this manual will be issued. These pages must be inserted in your parts manual as soon as they are received. Failure to keep your parts manuals up to date will result in confusion and may cause you to order wrong parts.

PART LIST

The **Index**, describes the item on the figure you are looking at. The **Part No.** is a numerical description of the item and the part ordering number. The **Part Name** is a description of the part number in alphabetical form. The **No.** is the quantity used on the machine.

EP EQUIPMENT CO.,LTD.

Address: XIAQUAN,DIPU,ANJI,ZHEJIANG,CHINA

Tel:400-880-2178

Net:www.ep-ep.com

Email:eparts@ep-ep.com

ALL RIGHT RESERVED COPYRIGHT

PM3214 11.21

零件订购说明

怎么样订购

当您订购的时候，您需要提供叉车零件的编号，数量，型号和序列号。提供这些信息能够保证您的订购更加的高效。

因为您的经销商有很多零件的存货，而且需要保持所有零件的价格是最新的，所以他会尽快地处理您的订购需求。假如因为某些原因，存货中没有这个零件，那么他会从公司订货。无论怎么样的情况，他手里都会有一份服务手册文件，它能提供所有可用的零件的订购信息或者技术信息。

订购地点

当您需要订购零件时，请到销售给您电动叉车的经销商那里订购。如果经销商有必要从公司订购零件，他能为您提供快捷的服务。根据您的订购信息，零件和它对应的操作说明会一起装好。

零件的退还说明

一般情况下，因为信用的关系，退还的零件没有事先的同意，是不会被公司认可的。我们不会对没有经过授权但退还过来的零件负责。

如果您有一些零件一定要退还，请联系您的经销商。若经销商确认零件可以退还，则其会安排授权要退还的零件。

技术修改

当叉车技术上有修改时，这本手册的修正页会重新发行。当您拿到这些修正页时，您一定要立即把它们插入到您的零件手册中。若没有及时的更新您的零件手册，则可能会导致您订购、维护等方面的错误。

零件清单

Index 描述的是在插图上，您要找的项目。**Part No.**是零件的一系列描述和它的订购号码。**Part Name** 是用文字的形式描述。**No.**代表的是零件在叉车上使用的数量。

浙江中力机械有限公司

地址：浙江省安吉县递铺镇霞泉

村中力园区

电话：400-880-2178

网址：www.ep-ep.com

邮箱：epparts@ep-ep.com

版权归本公司所有

PM3214 11.21

HOW TO READ PARTS MANUAL

怎么读取零件明目录

Tip 1:

A: The part of Index 10 is chosen by different tongue of the same series type.

Index 序号	Part No. 零件编号	Part Name 零件名称	No. 数量	Applied Date 适用日期	Remark 备注
-------------	------------------	-------------------	-----------	----------------------	--------------

9	0000-000539-00	Flatwasher Φ24 平垫	3		
10	3218-130000-00	Counter Weight 平衡重	1		CPD18TV
10	3220-130000-00	Counter Weight 平衡重	1		CPD20TV
10	3216-130000-00	Counter Weight 平衡重	1		CPD16TV
10	3215-130000-00	Counter Weight 平衡重	1		CPD15TV
10	3213-130000-00	Counter Weight 平衡重	1		CPD13TV
11	1220-150008-00	Screw 螺钉	2		

A ⇒

B: The part of Index 7 is **Optional**.

KIT	3115-WHK-0A02	Kit for slider 滑块修理包	1		
7	3218-800001-10	Fork 货叉	1		100*40*920
7	3218-800001-20	Fork 货叉	1		100*40*1070
7	3218-800001-30	Fork 货叉	1		100*40*1150
7	3218-800001-40	Fork 货叉	1		100*40*1200
8	3218-800002-00	Pin assembly 提拨销总成	2		

B ⇒

C: The **number** of Index 40 is chosen by the **actual requirements**.

39	3218-600006-00	Shock Absorber 减震垫	3		
40	3218-332002-00	Collar 旋转套筒	Req		

C ⇒

D: The part of Index 34 is cancelled because of the design perfect , and there is an new part which is make the use more perfect.

33	3218-330001-A0	Cushion 靠垫	1		
34	01 3218-330005-A0	Switch 指尖微动开关	4		Cancelled
	02 CK11-56003-00	JC100 Switch 拇指开关	4		
35	0000-000277-00	Bolt M8×25 螺栓	2		

D ⇒

E: The part of Index 19 has an **Applicability**, because it's our policy to constantly improve our products.

E-1: Record by time

- **053011** : Ending on May 30, 2011.
- 053011-** : Beginning on May 30, 2011.

E-2: Record by serial number

- S2016344** : Ending at S2016344
- S2016345-** : Starting at S2016345

There are three types of serial number:

1) 1 (LETTER)+ 7 (NUMBERS)

Applied Date: Up to February 1, 2015

2) 1 (LETTER)+ 8 (NUMBERS)

Applied Date: From February 1, 2015 to June 1, 2015

3) 1 (NUMBER)+ 8 (NUMBERS)

Applied Date: From June 1, 2015

Index	Part No.	Part Name	No.	Applied Date	Remark
序号	零件编号	零件名称	数量	适用日期	备注

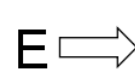

18	0000-000277-00	Bolt M8x25 螺栓	3		
19	01 3218-113000-00	Gas Spring 气弹簧后安装板	1	-053011	
	02 3218-113000-0A	Gas Spring 气弹簧后安装板	1	053011-	
20	3218-110007-00	Shock Absorber 地板减震垫	4		

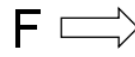

7	01	2125-410004-	Cap 导向套	1	-S2016344	
	02	2125-410004-	Cap 导向套	1	S2016345-	
8		0000-000084-	Ring Wiper 防尘圈	1		
9		0000-000370-	O-ring O型密封圈	1		

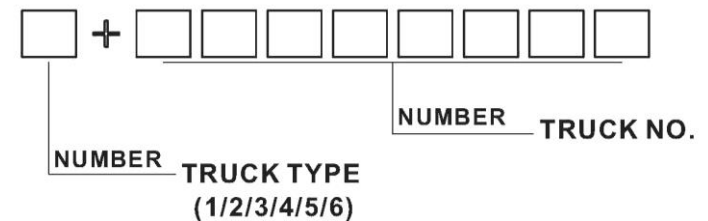
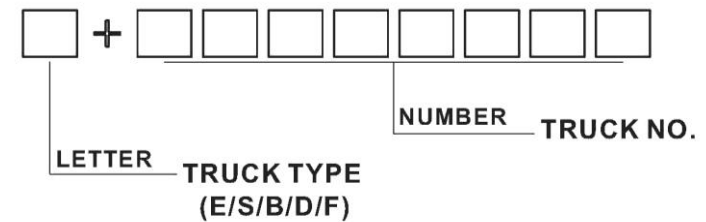
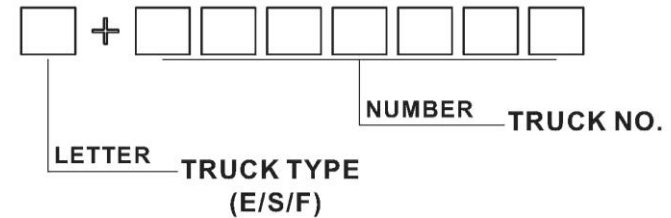

要点 1:

A: 同系车型中，序列 10 根据不同吨位进行选择。



Index 序号	Part No. 零件编号	Part Name 零件名称	No. 数量	Applied Date 适用日期	Remark 备注
9	0000-000539-00	Flatwasher Φ24 平垫	3		
10	3218-130000-00	Counter Weight 平衡重	1		CPD18TV
10	3220-130000-00	Counter Weight 平衡重	1		CPD20TV
10	3216-130000-00	Counter Weight 平衡重	1		CPD16TV
10	3215-130000-00	Counter Weight 平衡重	1		CPD15TV
10	3213-130000-00	Counter Weight 平衡重	1		CPD13TV
11	1220-150008-00	Screw 螺钉	2		

B: 序号 7 表示该零件有几个品种可供您的选择。



KIT	3115-WHK-0A02	Kit for slider 滑块修理包	1		
7	3218-800001-10	Fork 货叉	1		100*40*920
7	3218-800001-20	Fork 货叉	1		100*40*1070
7	3218-800001-30	Fork 货叉	1		100*40*1150
7	3218-800001-40	Fork 货叉	1		100*40*1200
8	3218-800002-00	Pin assembly 提拔销总成	2		

C: 序号 40 表示该零件的数量有实际需求决定。

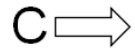

39	3218-600006-00	Shock Absorber 减震垫	3		
40	3218-332002-00	Collar 旋转套筒	Req		

D: 序号 34 表示由于设计完善要求，取消并由新的零件替换，。



33	3218-330001-A0	Cushion 靠垫	1		
34	01 3218-330005-A0	Switch 指尖微动开关	4		Cancelled
	02 CK11-56003-00	JC100 Switch 拇指开关	4		
35	0000-000277-00	Bolt M8x25 螺栓	2		

E: 序号 19 表示该零件有一个适用的时间范围。这是因为我们在不断地进行产品的升级。

E-1: 用时间记录

-053011 : 截止到 2011 年 5 月 30 日
053011- : 起始于 2011 年 5 月 30 日

E-2: 用序列号记录

-S2016344 : 截止序列号 S2016344
S2016345- : 起始序列号 S2016345

有三种序列号形式:

1) 1 (字母) + 7 (数字)

适用时间: 截止到 2015 年 2 月 1 日

Index 序号	Part No. 零件编号	Part Name 零件名称	No. 数量	Applied Date 适用日期	Remark 备注
18	0000-000277-00	Bolt M8x25 螺栓	3		
19	01 3218-113000-00	Gas Spring 气弹簧后安装板	1	-053011	
	02 3218-113000-0A	Gas Spring 气弹簧后安装板	1	053011-	
20	3218-110007-00	Shock Absorber 地板减震垫	4		

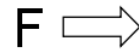

7	01 2125-410004-	Cap 导向套	1	-S2016344	
	02 2125-410004-	Cap 导向套	1	S2016345-	
8	0000-000084-	Ring Wiper 防尘圈	1		
9	0000-000370-	O-ring O型密封圈	1		

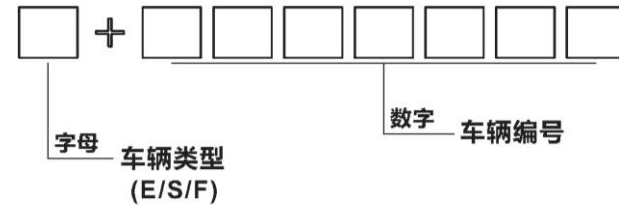

2) 1 (字母) + 8 (数字)

适用时间: 2015 年 2 月 1 日至 2015 年 6 月 1 日

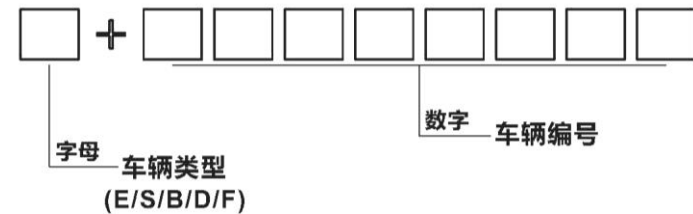

3) 1 (数字) + 8 (数字)

适用时间: 2015 年 6 月 1 日至今

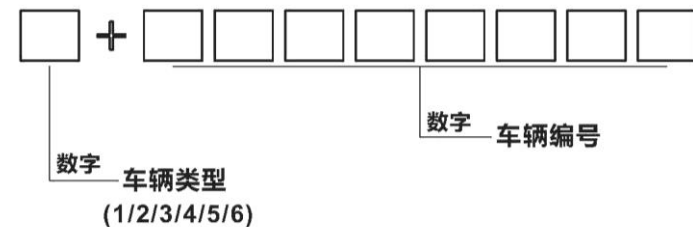

Tip 2

A: Section 0102 is the original version.

B: Section 010201 is the version that some parts in the Section 0102 have been changed.

C: Section 010202 is the version that some parts in the Section 010201 have been changed.

When you order, Please locate specific parts information of your truck by the Applied Date of parts in each version.

要点 2

A: 章节 0102 表示原始版本;

B: 章节 010201 表示在原始版本 (章节 0102) 上零件有所变更;

C: 章节 010202 表示在变更版本 (章节 010201) 上零件有所变更。

当您订购零件时, 请根据每个版本中零件的适用时间来判断您所选购车型的零件信息。

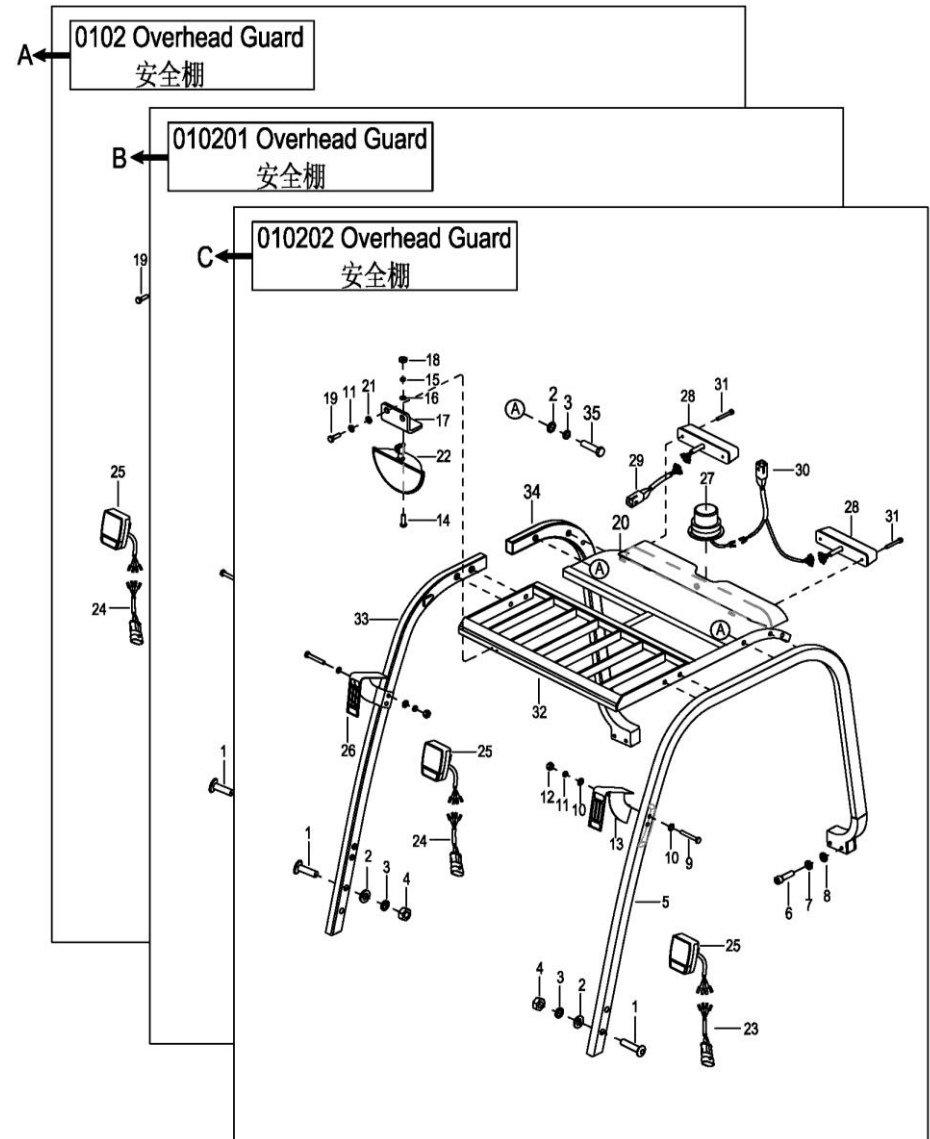

Index (目录)

1000 Frame System 车身系统	9
0101 Frame System 车身系统.....	10
0102 Overhead Guard 安全棚.....	13
0104 Back Cover 后外罩.....	17
2000 Operating Control System 操作系统	19
0201 Steering Control System 操作系统.....	20
0202 Parking Brake 脚制动.....	23
0203 Steering Assembly 转向柱总成.....	25
3000 Driving System 驱动系统	32
0301 Driving System 驱动系统.....	33
0302 Gearbox assembly 变速箱总成.....	35
0303 Driving Wheel 驱动轮.....	38
4000 Steering System 转向系统	40
0401 Rear Axle Steering Assembly 后桥转向总成.....	41
0402 Steering Axle 转向桥.....	43
0403 Steering Wheel 转向轮.....	45
5000 Electrical System 电气系统	47
0501 Electrical Components 电器元件.....	48
0502 Wiring Harness Assembly 线束总成.....	51
0503 Cable Assembly 电缆总成.....	53
0504 Lithium Battery Assembly 锂电池总成.....	55
6000 Hydraulic System 液压系统	58
0601 Hydraulic System I 液压管路 I.....	59
0602 Hydraulic System II 液压管路 II.....	61
0603 Oil Tank 油箱.....	64
9000 Addendum 附录	66
0901 Label 标贴.....	67

1000
Frame System
车身系统

0101 Frame System

车身系统

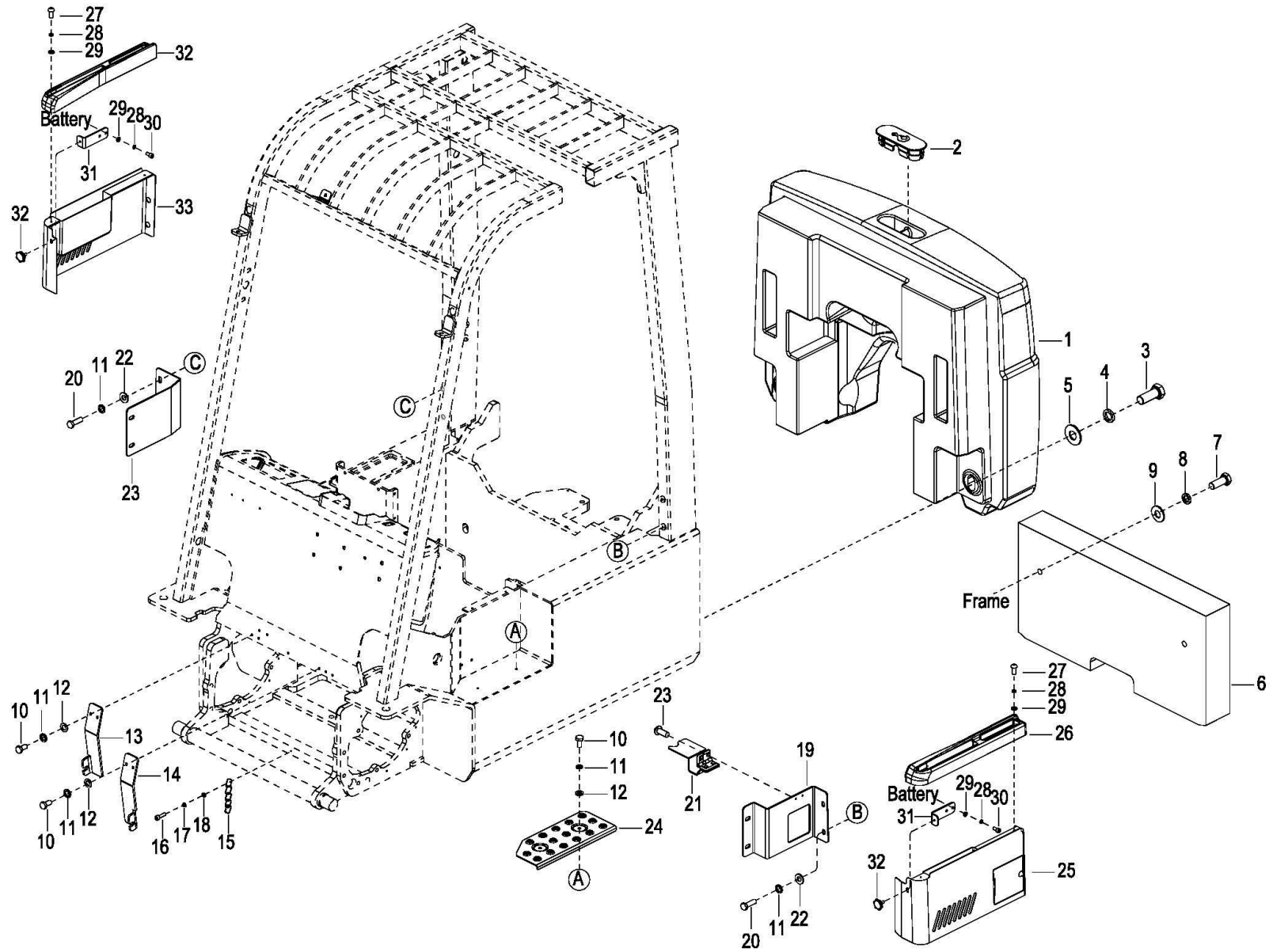

0101 Frame System

车身系统

Index 序号	Part No. 零件编号	Part Name 零件名称	No. 数量	Applied Date 适用日期	Remark 备注
1	3214-130001-00	Counterweight 配重	1		CPD15/18TVL
1	3216-130001-00	Counterweight 配重	1		CPD20TVL
2	3125-100009-00	Lifting Hole Cover 起吊孔盖	1		
3	301000000217	Bolt M24x70 螺栓	2		
4	304000000058	Lockwasher Φ24 弹垫	2		
5	304001000008	Flatwasher Φ24 平垫	2		
6	3216-130002-00	Counterweight 副配重	1		
7	301002000065	Bolt M20x70 螺栓	2		
8	304000000057	Lockwasher Φ20 弹垫	2		
9	304000000099	Flatwasher Φ20 平垫	2		
10	301002000013	Bolt M8x16 螺栓	6		
11	304000000052	Lockwasher Φ8 弹垫	14		
12	304000000040	Flatwasher Φ8 平垫	10		
13	3214-100001-00	lasso Holder L 制动拉索左固定板	1		
14	3214-100002-00	lasso Holder R 制动拉索右固定板	1		
15	3112-100033-00	Chain 静电链条	1		
16	302001000006	Screw M4x10 螺钉	1		
17	304000000048	Lockwasher Φ4 弹垫	1		
18	304000000038	Flatwasher Φ4 平垫	1		
19	3216-121000-00	Mounting plate L 左侧安装板	1		CPD18/20TVL
19	3214-121000-00	Mounting plate L 左侧安装板	1		CPD15TVL
20	301002000016	Bolt M8x30 螺栓	8		
21	3701-130000-00	Charger Cover 充电舱盖组件	1		CPD18/20TVL
21	3112-191000-D0	Charger Cover 充电舱盖组件	1		CPD15TVL
22	304000000033	Flatwasher Φ8 大垫圈	4		
23	3216-100004-00	Mounting plate R 右侧安装板	1		CPD18/20TVL

23	3214-100004-00	Mounting plate R	右侧安装板	1		CPD15TVL
24	3214-200001-00	Pedal	踏板	1		
25	3216-221000-00	Side Plate L	左侧板焊件	1		CPD18/20TVL,For Oversea
26	3216-220002-00	Upper Cover L	左侧上罩	1		CPD18/20TVL,For Oversea
27	302002000011	Screw M6x16	螺钉	4		
28	304000000050	Lockwasher Φ6	弹垫	8		
29	304000000036	Flatwasher Φ6	平垫	8		
30	302001000110	Screw M6x16	螺钉	4		
31	3216-220001-00	Fixing Plate	侧板固定板	1		CPD18/20TVL,For Oversea
32	3216-230002-00	Upper Cover R	右侧上罩	1		CPD18/20TVL,For Oversea
33	3216-231000-00	Side Plate R	右侧板焊件	1		CPD18/20TVL,For Oversea

0102 Overhead Guard

安全棚

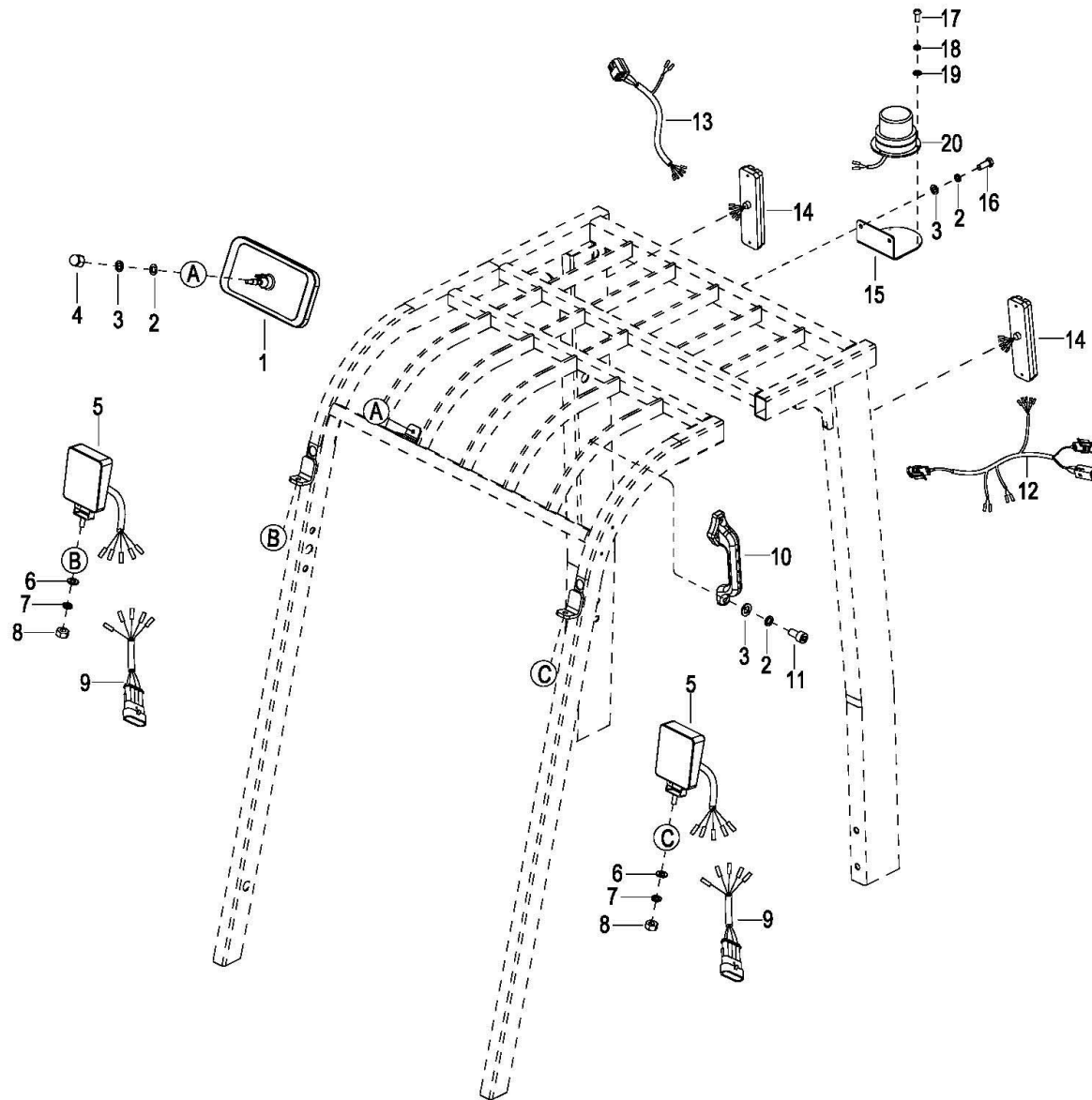

0102 Overhead Guard

安全棚

Index 序号	Part No. 零件编号	Part Name 零件名称	No. 数量	Applied Date 适用日期	Remark 备注
1	3125-122000-00-01	Retroreflector 反光镜	1		
2	304000000052	Lockwasher Φ 8 弹垫	5		
3	304000000040	Flatwasher Φ 8 平垫	5		
4	303001000005	Nut M8 螺母	1		
5	3130-680100-10	Head Lamp LED 前照灯	2		
6	304002000006	Flatwasher Φ 10 平垫	2		
7	304000000053	Lockwasher Φ 10 弹垫	2		
8	303001000006	Nut M10 螺母	2		
9	3214-622000-00	Front Lamp Harness 前灯线束	2		
10	3218-600009-00	Handrail 喇叭开关扶手	1		
11	302001000106	Screw M8x16 螺钉	2		
12	3214-623000-00	Back Lamp Harness L 后灯左线束	1		
13	3214-625000-00	Back Lamp Harness R 后灯右线束	1		
14	3525-680003-00	Rear Lamp Unit LED 尾灯	2		
15	3112-100019-00	Caution Lamp Plate 警示灯安装板	1		
16	301002000013	Bolt M8x16 螺栓	2		
17	302004000027	Screw M4x12 螺钉	3		
18	304000000048	Lockwasher Φ 4 弹垫	3		
19	304000000038	Flatwasher Φ 4 平垫	3		
20	3218-600400-00	Caution Lamp LED 频闪警灯	1		

0103 Front Cover
前外罩

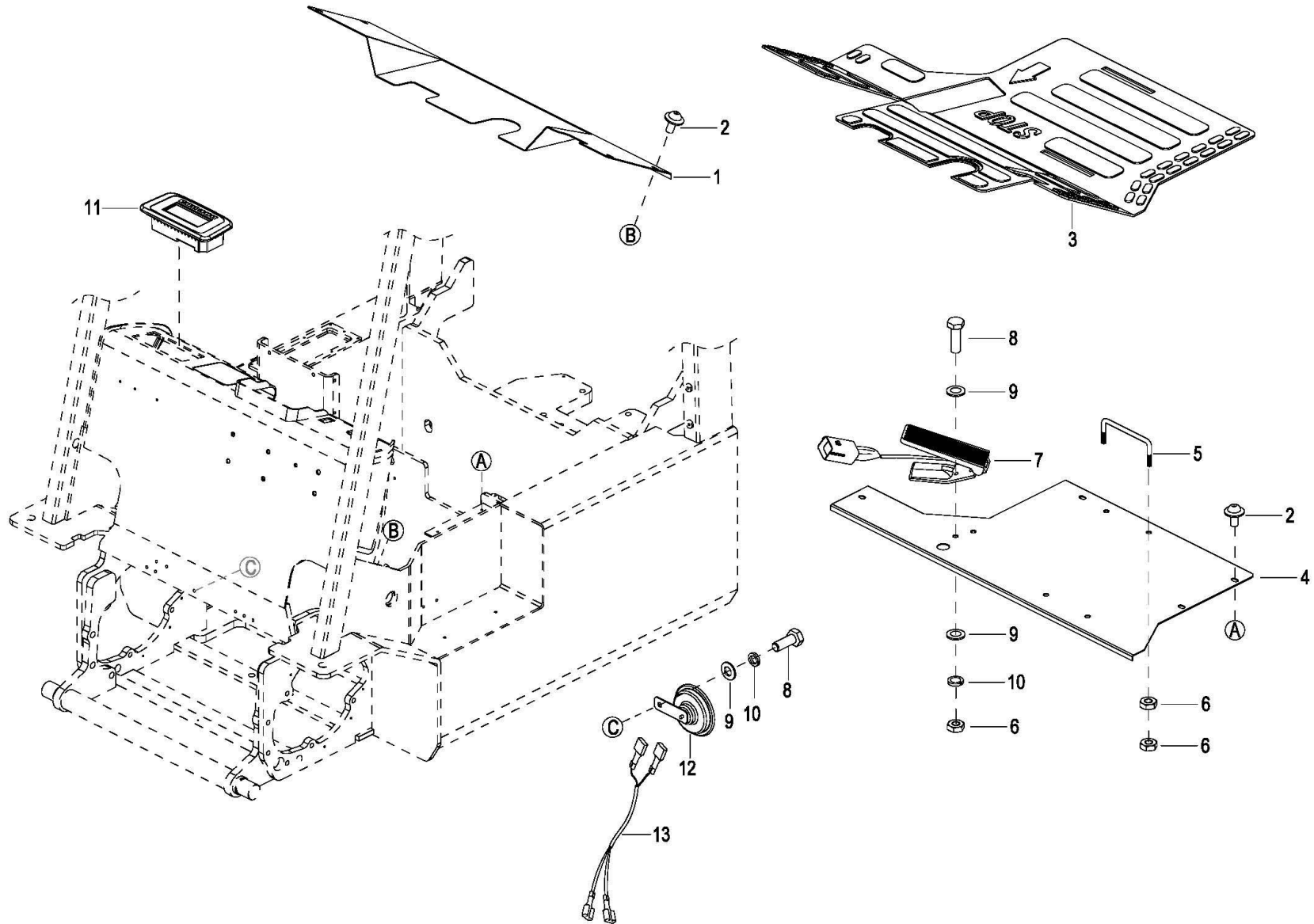

0103 Front Cover

前外罩

Index 序号	Part No. 零件编号	Part Name 零件名称	No. 数量	Applied Date 适用日期	Remark 备注
1	3214-231000-00	Floor Board 前地板	1		
2	202800000073	Screw M8x20 螺钉	8		
3	3214-200004-00	Rubber pad 地板橡胶垫	1		
4	3214-221000-00	Floor Board 后地板	1		
5	3218-240001-00	Rod 前地板螺纹拉杆	2		
6	303001000005	Nut M8 螺母	10		
7	3218-680000-10	Accelerator 加速器	1		
8	301002000014	Bolt M8x20 螺栓	3		
9	304000000040	Flat washer $\varnothing 8$ 平垫	5		
10	304000000052	Lockwasher $\Phi 8$ 弹垫	3		
11	3218-600007-50	Meter 仪表	1		
12	3218-600500-00	Speaker 喇叭	1		
13	3312-730004-00	Filter harness 叉车喇叭滤波器线束	1		

0104 Back Cover

后外罩

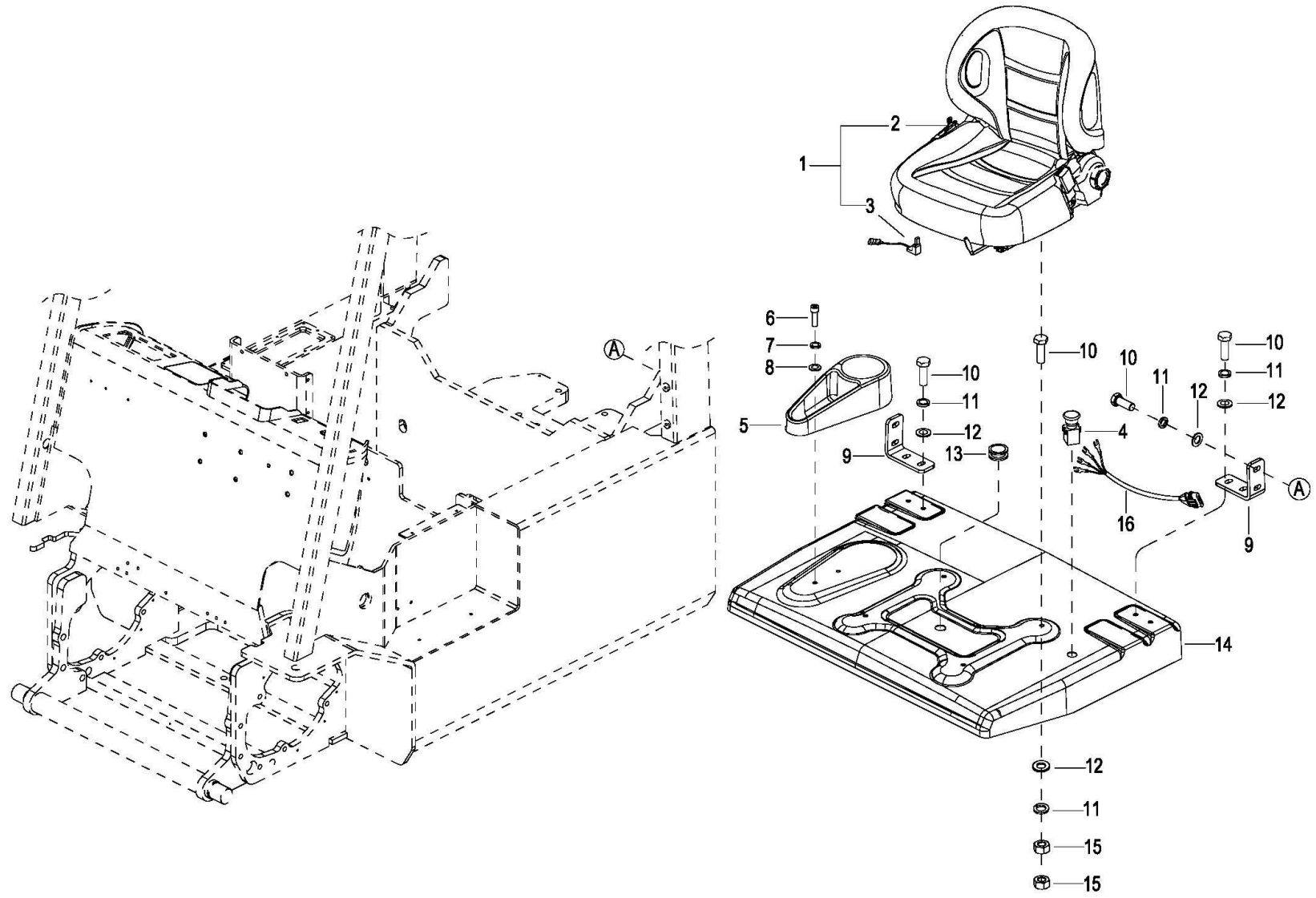

0104 Back Cover

后外罩

Index 序号	Part No. 零件编号	Part Name 零件名称	No. 数量	Applied Date 适用日期	Remark 备注
1	3218-212000-10	Seat 座椅	1		
2	3218-212001-10	Seat belt 安全带	1		
3	3125-600200-10	Seat switch 座椅微动开关	1		
4	1113-500012-E2	Emergency Stop Switch 急停开关	1		
5	3214-200003-00	Cup Holder 茶杯座	1		
6	302001000018	Screw M6x20 螺钉	2		
7	304000000050	Lockwasher Φ6 弹垫	2		
8	304000000036	Flatwasher Φ6 平垫	2		
9	3214-100003-00	Mounting plate 电瓶盖板安装板	2		
10	301002000016	Bolt M8x30 螺栓	8		
11	304000000052	Lockwasher Φ8 弹垫	8		
12	304000000082	Flatwasher Φ8 大平垫	8		
13	3125-210001-00	Washer Φ25 走线圈	1		
14	3216-211000-00	Battery Cover 电瓶盖板	1		
14	3214-211000-00	Battery Cover 电瓶盖板	1		
15	303001000005	Nut M8 螺母	8		
16	3214-626000-00	Emergency Stop Switch Wire 急停转接线线束	1		

2000

Operating Control System

操作系统

0201 Steering Control System

操作系统

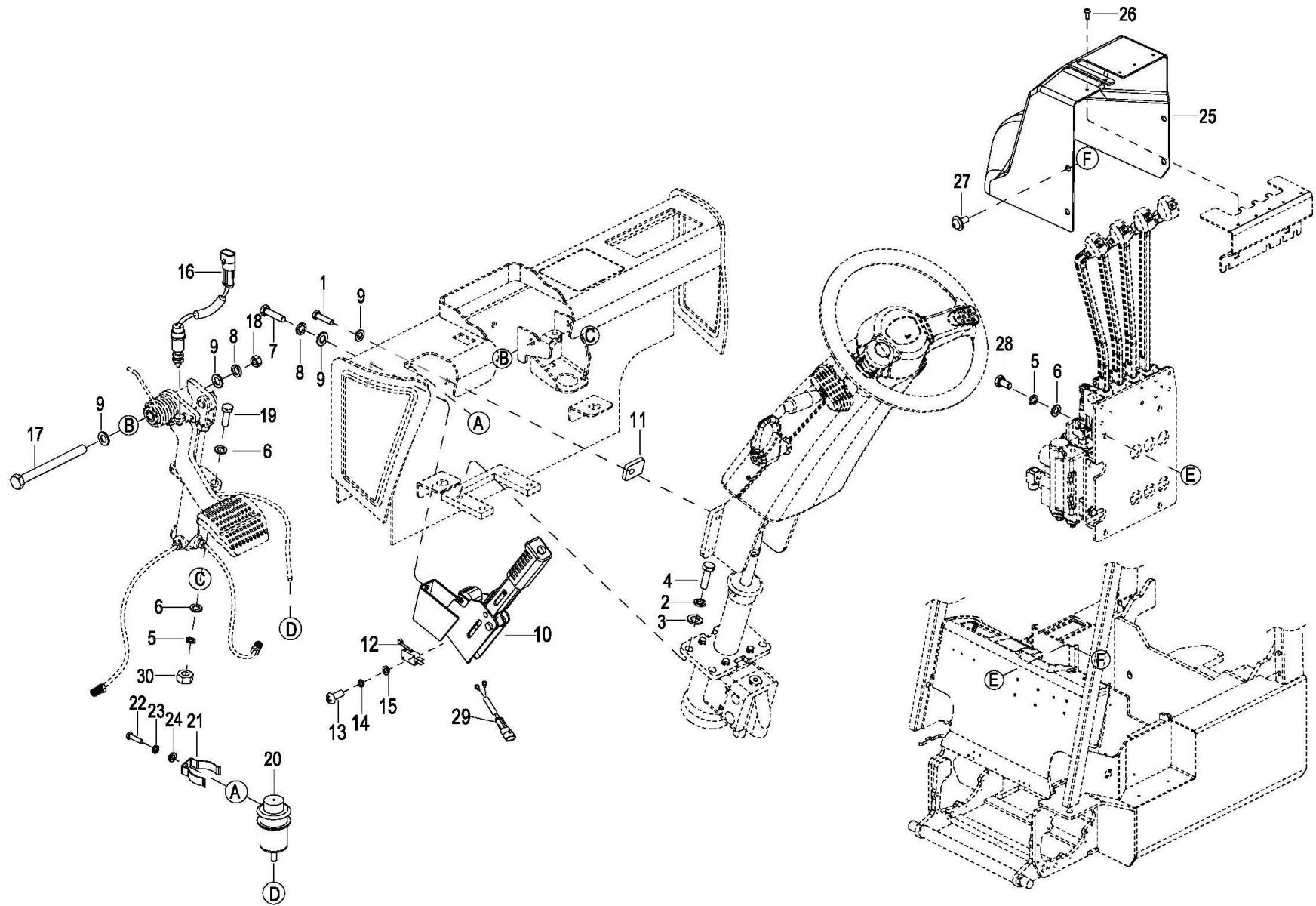

0201 Steering Control System

操作系统

Index 序号	Part No. 零件编号	Part Name 零件名称	No. 数量	Applied Date 适用日期	Remark 备注
1	301002000028	Bolt M10x30 螺栓	4		
2	304000000051	Lockwasher Φ12 弹垫	2		
3	304000000041	Flatwasher Φ12 平垫	2		
4	301002000037	Bolt M12x30 螺栓	4		
5	304000000052	Lockwasher Φ8 弹垫	4		
6	304000000040	Flatwasher Φ8 平垫	6		
7	301002000027	Bolt 10x25 螺栓	4		
8	304000000053	Lockwasher Φ10 弹垫	3		
9	304002000006	Flatwasher Φ10 平垫	8		
10	3132-650010-00	Parking Lever Assembly 手制动总成	1		
11	3218-600006-00	Shock Absorber 橡胶垫	2		
12	3132-605000-00	Switch 微动开关	1		
13	302000000118	Screw M3x30 螺钉	2		
14	304000000047	Lockwasher Φ3 弹垫	2		
15	304000000037	Flatwasher Φ3 平垫	2		
16	3218-601000-00	Brake Switch Harness 制动开关线束	1		
17	301000000085	Bolt M10x110 螺栓	1		
18	303000000013	Nut M10 螺母	1		
19	301002000016	Bolt M8x30 螺栓	2		
20	3218-315000-00	Cup 制动油杯	1		
21	3120-310001-00	Cup Plate 制动油杯安装板	1		
22	302001000018	Screw M6x20 螺钉	1		
23	304000000050	Lockwasher Φ6 弹垫	1		
24	304000000036	Flatwasher Φ6 平垫	1		

25		3214-200002-00	Valve Cover	多路阀罩	1		Two
25		3214-200002-10	Valve Cover	多路阀罩	1		Three
25		3214-200002-20	Valve Cover	多路阀罩	1		Four
26		302002000007	Screw M5x10	螺钉	5		
27		202800000073	Screw M8x20	螺钉	4		
28		301002000014	Bolt M8x20	螺栓	4		
29		3125-635000-00	Hand Brake Harness	手刹开关线束	1		
30		303001000005	Nut M8	螺母	2		

0202 Parking Brake
脚制动

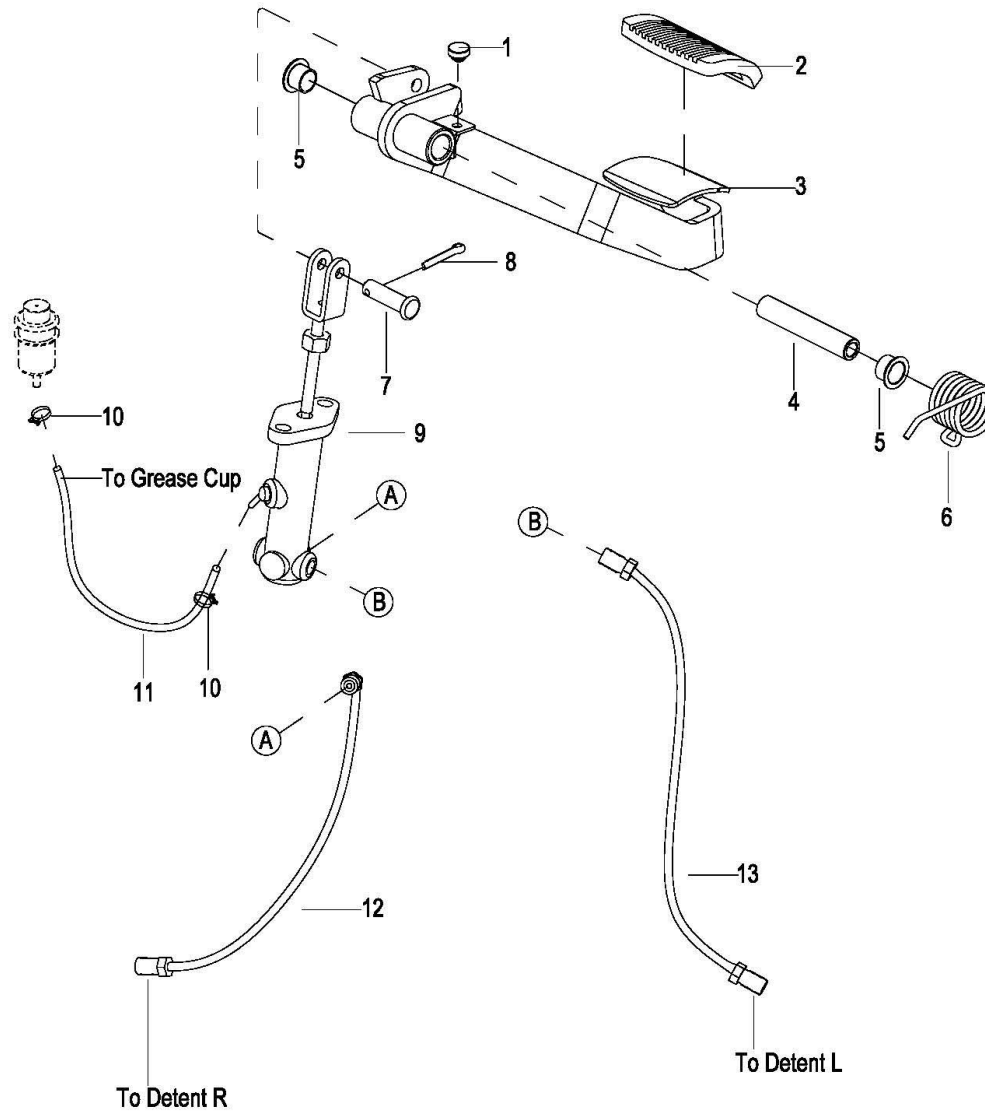

0202 Parking Brake

脚制动

Index 序号	Part No. 零件编号	Part Name 零件名称	No. 数量	Applied Date 适用日期	Remark 备注
1	3125-310006-00	Rubber Washer 缓冲垫	1		
2	3125-310005-00	Treadle Washer 脚踏板垫	1		
3	3214-314000-00	Pedal,brake 制动踏板	1		
4	3125-310001-00	Bushing 长轴套	1		
5	3125-310002-00	Bushing 脚刹自润滑铜套	2		
6	3125-310003-00	Spring 脚制动弹簧	1		
7	307006000009	Pin $\Phi 8 \times 30$ 销轴	1		
8	307001000002	Pin $\Phi 2 \times 20$ 开口销	1		
9	3515-310009-00	Master Cylinder 制动总泵	1		
10	202800000065	Clip $\Phi 10-16$ 卡箍	2		
11	3218-310001-00	Vitta 制动橡胶管	1		
12	3218-310005-00	Vitta II 制动软管 II	1		Right
13	3218-310004-00	Vitta I 制动软管 I	1		Left

0203 Steering Assembly
转向柱总成

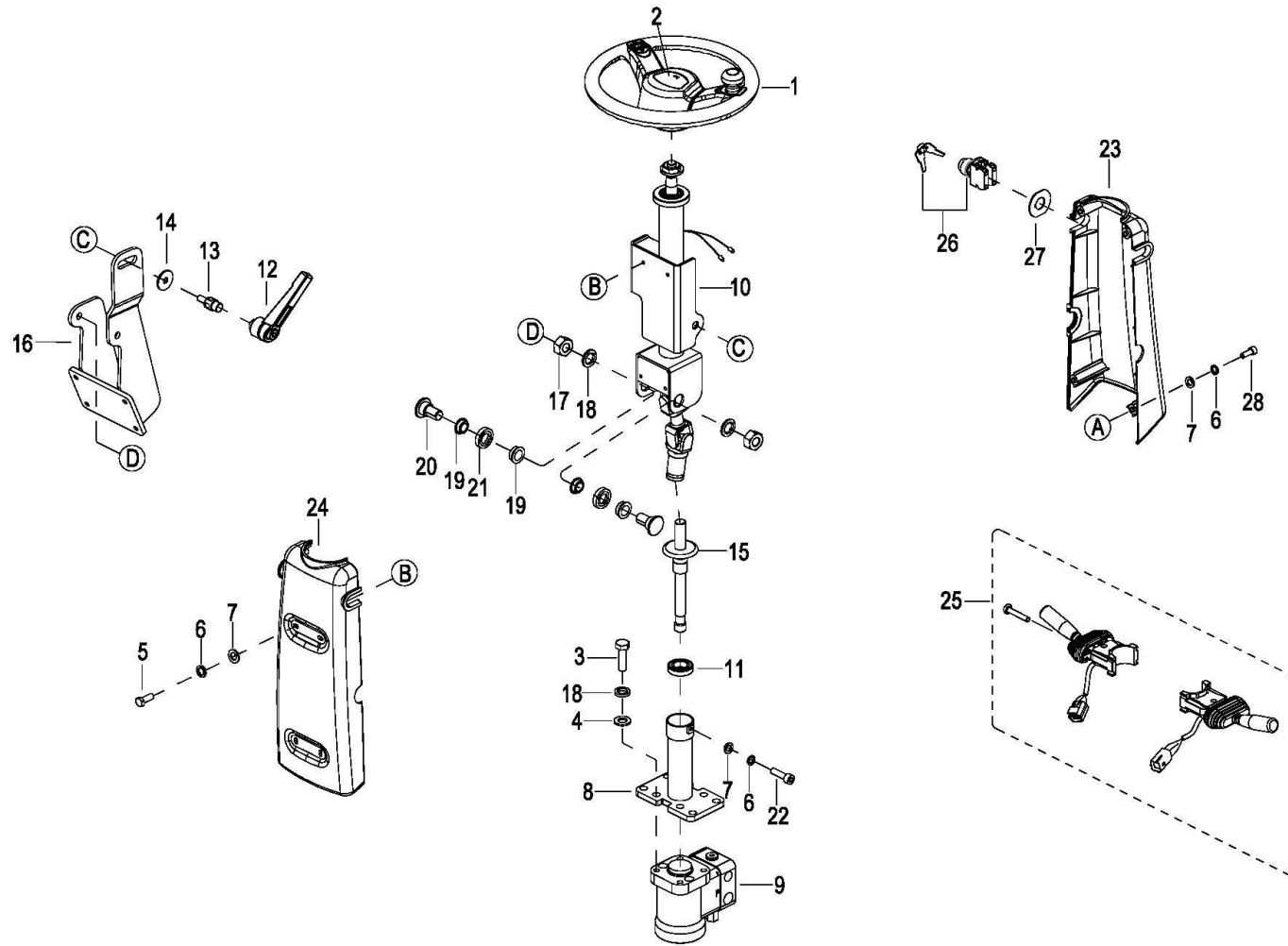

0203 Steering Assembly

转向柱总成

Index 序号	Part No. 零件编号	Part Name 零件名称	No. 数量	Applied Date 适用日期	Remark 备注
1	3218-323000-10	Steering Wheel 方向盘	1		Including #2
2	3218-323030-10	Hornhood 喇叭盖	1		
3	301002000027	Bolt M10x25 螺栓	4		
4	304002000006	Flat Washer Φ10 平垫	4		
5	301002000003	Bolt M6x12 螺栓	4		
6	304000000050	Lockwasher Φ6 弹垫	13		
7	304000000036	Flatwasher Φ6 平垫	13		
8	3218-312100-00	Redirector Bracket 转向器安装板组件	1		
9	3114-740000-00	Redirector 转向器	1		
10	3112-321000-10	Steering Column 转向管柱总成	1		
11	309001000012	Bearing 61905-2Z 轴承	1		
12	3218-320008-10	The Handle 锁紧手柄	1		
13	3218-320005-0A	Axis II 锁紧轴 II	1		
14	3218-320015-0B	Washer 锁紧螺栓垫片	1		
15	3218-325000-00	Steering Shaft 下转向轴组件	1		
16	3112-322000-10	Steering Bracket 转向管柱安装板	1		
17	303019000007	Nut M10 螺母	2		
18	304003000006	Lock Washer Φ10 弹垫	6		
19	3218-320013-00	Steering Bush 转向柱旋转衬套	4		
20	3218-320014-0A	Steering bolt 转向柱旋转螺栓	2		
21	3218-320007-00	Steering Washer 转向柱旋转垫圈	2		
22	302001000107	Screw M6x12 螺钉	1		
23	3112-320002-10	Cover, back 方向柱后罩	1		

0203 Steering Assembly

转向柱总成

Index 序号	Part No. 零件编号	Part Name 零件名称	No. 数量	Applied Date 适用日期	Remark 备注
24	3112-320001-10	Cover, front 方向柱前罩	1		
25	3218-600900-00	Swith 组合开关	1		
26	3112-603000-00	Key Lock 钥匙开关组件	1		
27	3112-320005-10	Plate 钥匙安装板	1		
28	302001000020	Screw M6x35 螺钉	4		

0204 Valve Control Linkage

多路阀操作杆

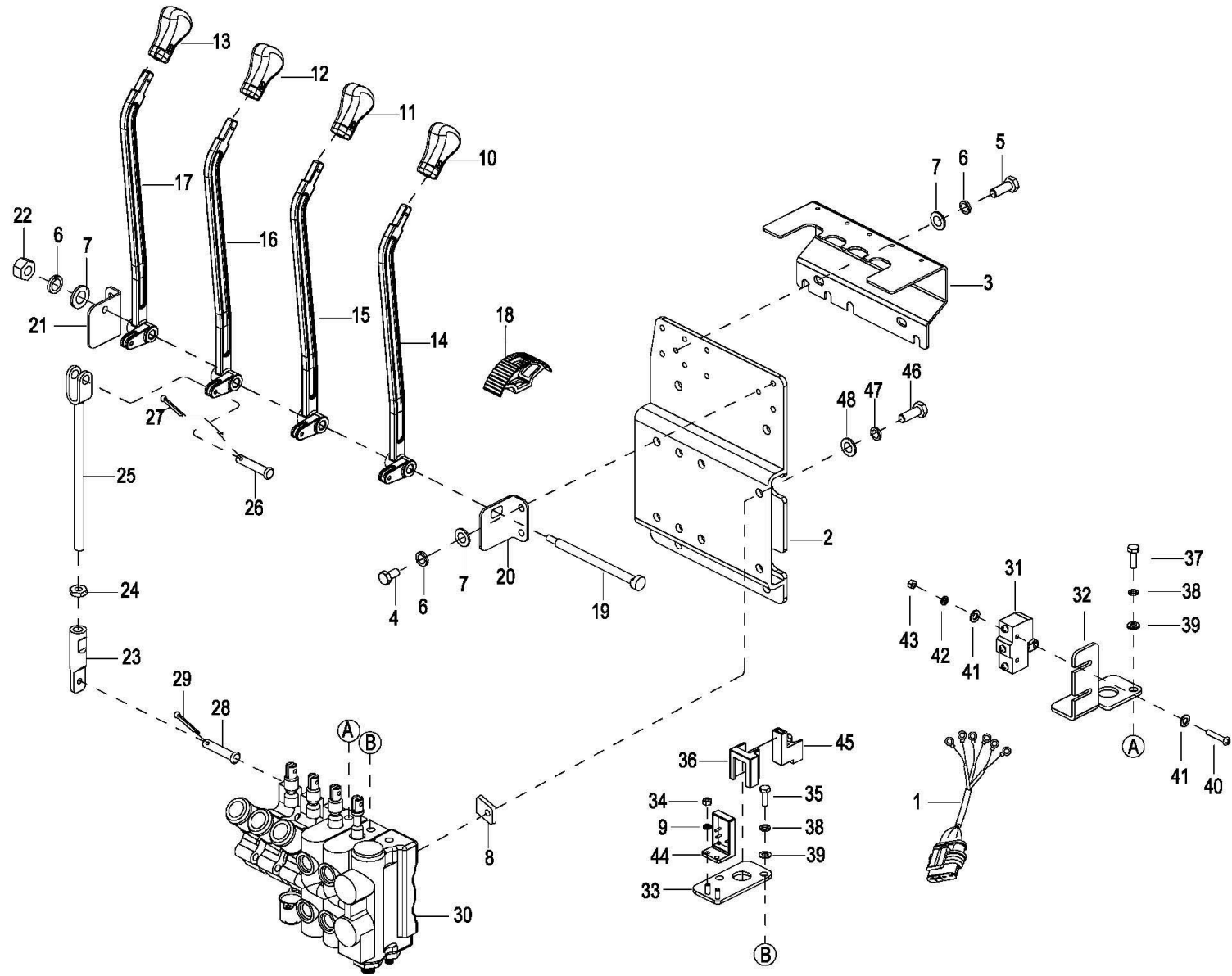

0204 Valve Control Linkage

多路阀操作杆

Index 序号	Part No. 零件编号	Part Name 零件名称	No. 数量	Applied Date 适用日期	Remark 备注
1	3218-628000-00	Switch Harness 泵开关线束	1		Two
1	3218-627000-00	Switch Harness 泵开关线束	1		Three
1	3218-629000-00	Switch Harness 泵开关线束	1		Four
2	3214-141000-00	Bracket 多路阀安装板	1		
3	3214-100006-00	Valve Plate 多路阀封板	1		
4	301002000013	Bolt M8×16 螺栓	4		
5	301002000014	Bolt M8×20 螺栓	4		
6	304000000052	Lockwasher ø8 弹垫	9		
7	304000000040	Flatwasher ø8 平垫	9		
8	3218-600006-00	Shock Absorber 橡胶垫	4		
9	304000000048	Lockwasher ø4 弹垫	2		
10	3131-310001-0A	Knob-Lifting 起升手柄	1		
11	3131-310002-0A	Knob-Tilt 倾斜手柄	1		
12	3131-310003-0A	Knob-Sway 侧移手柄	1		Option(1)
13	3131-310004-0A	Knob-Attachment 属具手柄	1		Option(2)
14	3131-310007-00	Control Lever,Lifting 一联杆	1		
15	3131-310008-00	Control Lever,Tilt 二联杆	1		
16	3131-310009-00	Control Lever,Sway 三联杆	1		Option(1)
17	3131-310010-00	Control Lever,Attachment 四联杆	1		Option(2)
18	3131-310013-00	Valve lever slide 阀杆滑块	4		
19	3131-310011-01	Pin Shaft 旋转销钉	1		Two
19	3131-310011-02	Pin Shaft 旋转销钉	1		Three,Option(1)
19	3131-310011-00	Pin Shaft 旋转销钉	1		Four,Option(2)
20	3525-330007-00	Holder II 轴套固定搭子 II	1		

21	3525-330006-00	Holder I	轴套固定搭子 I	1		
22	303022000004	Nut M8	螺母	1		
23	3525-330005-00	Joint	挺杆螺纹套	4		
24	303000000046	Nut M8	螺母	4		
25	3628-312001-00	Rod-Control Valve	多路阀挺杆	4		
26	307006000003	Pin Shaft $\varnothing 8 \times 25$	销轴	4		
27	307001000002	Pin $\varnothing 2 \times 20$	开口销	4		
28	3131-310012-00	Pin Shaft	销轴	4		
29	307000000054	Pin $\varnothing 1.5 \times 20$	开口销	4		
30	3218-730000-10	Control Valve Two	两联多路阀	1		
30	3218-730000-20	Control Valve Three	三联多路阀	1		
30	3218-730000-30	Control Valve Four	四联多路阀	1		
31	3218-605000-10	Switch	微动开关	3		
32	3218-337000-10	Bracket	微动开关安装板	3		
33	3112-311001-D0	Bracket	固定板	1		
34	303000000055	Nut M4	螺母	2		
35	301002000003	Bolt M6 \times 12	螺栓	2		
36	3112-100034-00	Buckle	防转卡扣	1		
37	301000000090	Bolt M6 \times 16	螺栓	6		
38	304000000050	Lockwasher $\Phi 6$	弹垫	8		
39	304000000036	Flatwasher $\Phi 6$	平垫	8		
40	302000000118	Screw M3 \times 30	螺钉	6		
41	304000000047	Lockwasher $\Phi 3$	弹垫	12		
42	304000000037	Flatwasher $\Phi 3$	平垫	8		
43	303000000028	Nut M3	螺母	Req.		
44	3112-604000-00	Proportional potentiometer	比例电位器	1		Just for lifting
45	3112-608000-00	Magnet buckle	一联磁铁卡扣	1		Just for lifting
46	301002000027	Bolt M10 \times 25	螺栓	3		

47		304000000053	Lockwasher ø10	弹垫	3		
48		304002000006	Flatwasher ø10	平垫	3		

3000

Driving System

驱动系统

0301 Driving System
驱动系统

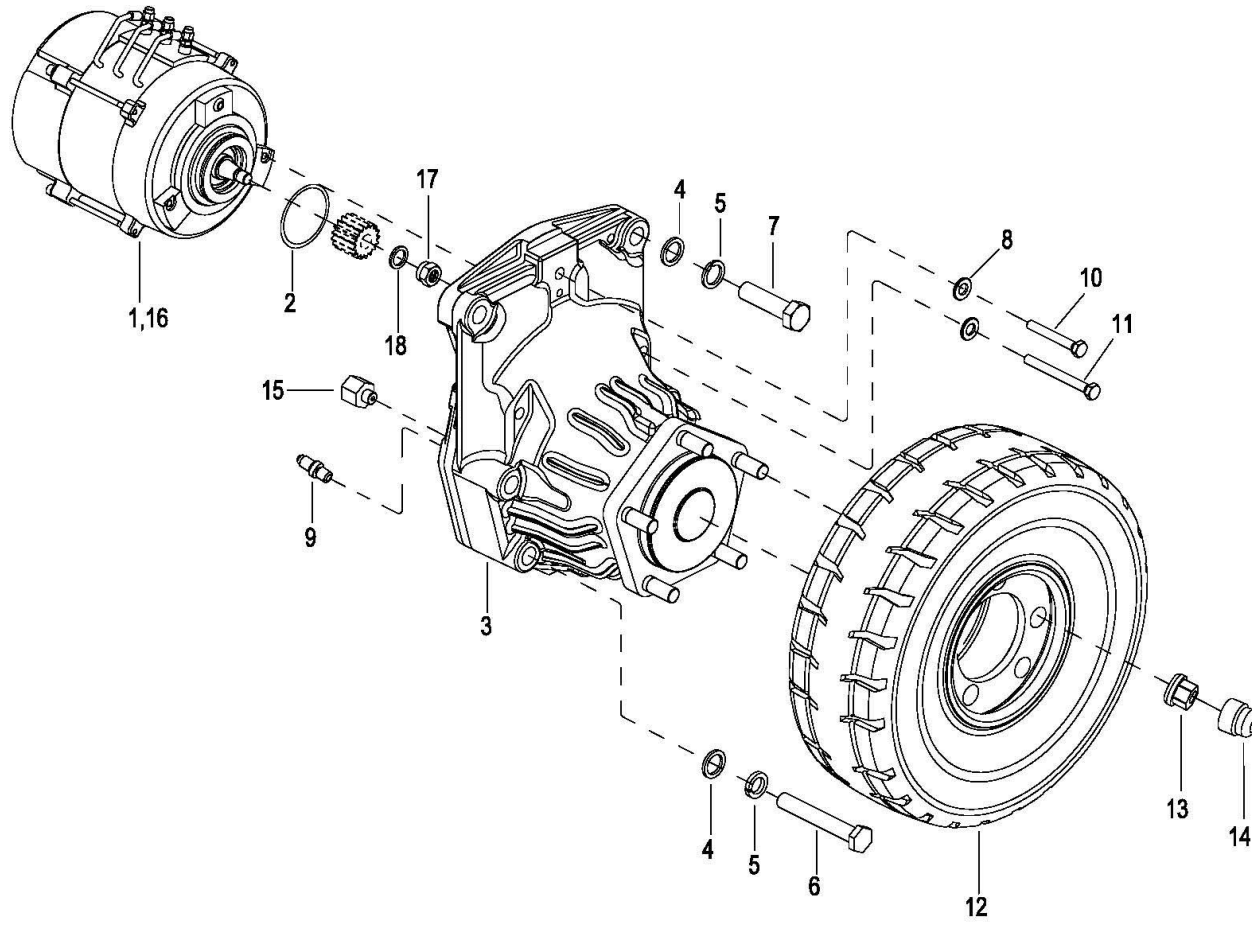

0301 Driving System

驱动系统

Index 序号	Part No. 零件编号	Part Name 零件名称	No. 数量	Applied Date 适用日期	Remark 备注
1	3214-650000-00	Traction Motor 驱动电机	2		5.0KW
2	3218-410001-00	O-Ring O 型圈	2		
3	3218-410000-00	Gearbox Assembly 变速箱	2		GP21
4	304002000008	Flatwasher Φ14 平垫	14		
5	304003000008	Lockwasher Φ14 弹垫	14		
6	301000000206	Bolt M14×95 螺栓	10		
7	301000000212	Bolt M14×55 螺栓	4		
8	304002000005	Flatwasher Φ8 平垫	6		
9	3218-410046-00	Vent valve 排气阀	2		
10	301002000022	Bolt M8×60 螺栓	2		
11	301002000025	Bolt M8×80 螺栓	4		
12	3218-420000-00	Driving Wheel 驱动轮	2		18*7-8/4.3R-8, With Trace
12	3218-420000-30	Driving Wheel 驱动轮	2		18*7-8/4.3R-8, Without Trace
12	3220-420000-10	Driving Wheel 驱动轮	2		200/50-10/6.50F-10, With Trace
12	3220-420000-30	Driving Wheel 驱动轮	2		200/50-10/6.50F-10, Without Trace
13	3218-400002-00	Nut 螺母	10		
14	3218-400003-00	Nut Cover 螺母套	10		
15	3218-400001-00	Joint 过渡接头	2		
16	3214-65001X-00	Encoder 编码器	2		
17	3214-65002X-00	Nut 螺母	2		
18	304000000042	Washer 垫圈	2		

0302 Gearbox assembly

变速箱总成

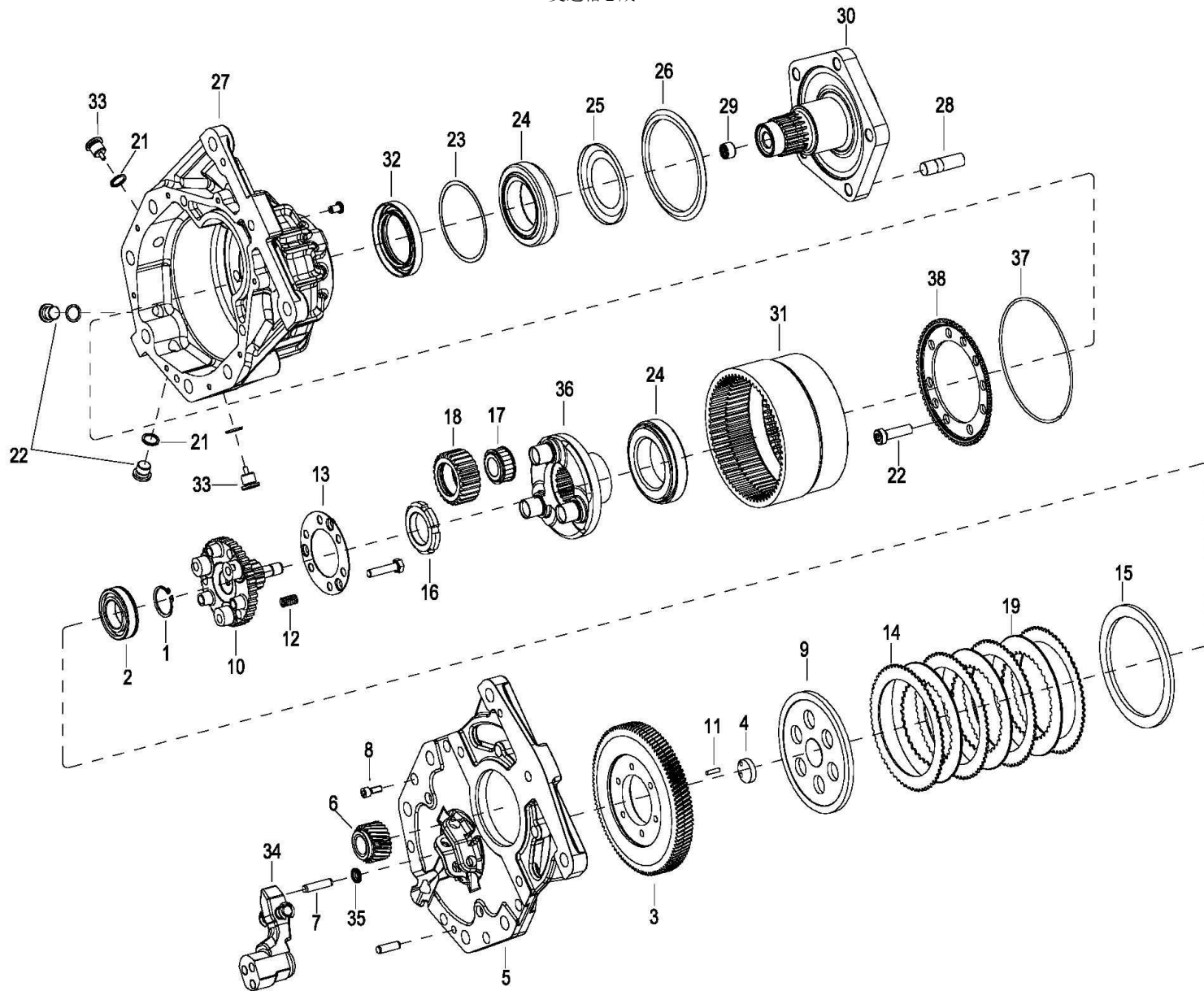

0302 Gearbox assembly

变速箱总成

Index 序号	Part No. 零件编号	Part Name 零件名称	No. 数量	Applied Date 适用日期	Remark 备注
1	3218-410002-00	Circlip 30×1.5 弹性挡圈	1		
2	3218-410003-00	Grooved Ball Bearing 沟槽球轴承	1		
3	3218-410004-00	helical gear 大齿轮	1		
4	3218-410005-00	axial bearing 轴承	1		
5	3218-410006-00	Housing Cover 遮盖	1		
6	3218-410008-00	Drive Pinion 传动小齿轮	1		
7	3218-410009-00	Pin 销	1		
8	3218-410010-00	Screw 螺钉	8		
9	3218-410011-00	Pressure Disc 压力垫圈	1		
10	3218-410012-00	Inner Disc Carrier 内阀片托架	1		
11	3218-410013-00	Cylindrical Pin 销	1		
12	3218-410014-00	Pressure Spring 压力弹簧	3		
13	3218-410015-00	Fixing Plate 固定板	1		
14	3218-410016-00	Outer Clutch Disc 外离合器压盘	4		
15	3218-410018-00	Pressure Disc Set 压力设定阀瓣	1		
16	3218-410019-00	Slotted Nut 开槽螺母	1		
17	3218-410020-00	Cylindrical Roller Bearing 圆柱滚子轴承	3		
18	3218-410021-00	Planet Gear 行星齿轮	3		
19	3218-410022-00	Inner Clutch Disk 内离合器压盘	3		
20	3218-410023-00	Torx-Screw 内梅花头螺钉	10		
21	3218-410024-00	Sesling ring 密封环	4		
22	3218-410025-00	Screw Plug 螺旋塞	2		
23	3218-410026-00	Shim Plate 环套垫片	1		
24	3218-410027-00	Tapered Roller Bearing 圆锥滚子轴承	1		

0302 Gearbox assembly

变速箱总成

Index 序号	Part No. 零件编号	Part Name 零件名称	No. 数量	Applied Date 适用日期	Remark 备注
25	3218-410028-00	NILOS-Ring 尼龙圈	1		
26	3218-410029-00	Seeling Ring 垫圈	1		
27	3218-410030-00	Housing 壳体	1		
28	3218-410032-00	Wheel Bolt 螺栓	5		
29	3218-410033-00	Needle Sleeve 滚针轴承	1		
30	3218-410034-00	Gear shaft 齿轮轴	1		
31	3218-410035-00	Internal Gear 内齿轮	1		
32	3218-410036-00	Shaft Sealing Ring 轴用密封圈	1		
33	3218-410037-00	Screw Plug With Magnet 磁性螺旋塞	2		
34	3218-410038-00	Brake Lever, Complete 制动杆	1		
35	3218-410039-00	Shaft Sealing Ring 轴用密封圈	1		
36	3218-410040-00	planet carrier 行星齿轮架	1		
37	3218-410041-00	FEY-ring FEY 密封圈	1		
38	3218-410042-00	Toothed Disc 齿盘	1		

0303 Driving Wheel
驱动轮

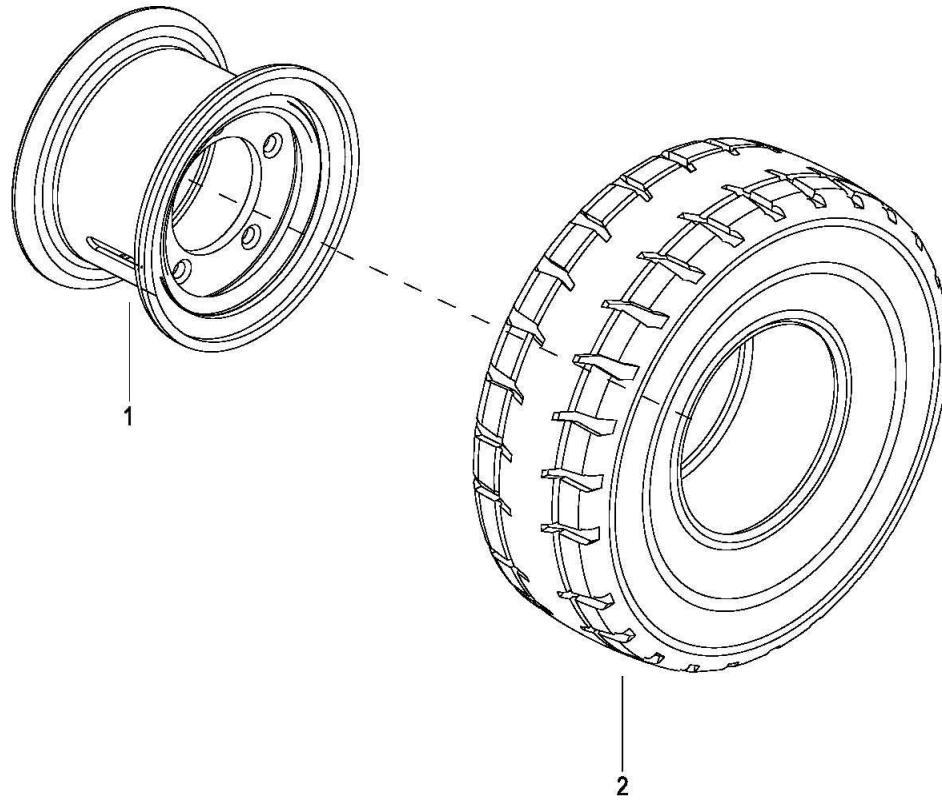

0303 Driving Wheel

驱动轮

Index 序号	Part No. 零件编号	Part Name 零件名称	No. 数量	Applied Date 适用日期	Remark 备注
1	3218-421000-00	Rim Set 轮辋	1		
2	3218-420001-00	Front Tires 前轮胎	1		18*7-8/4.3R-8, With Trace
2	3218-420001-30	Front Tires 前轮胎	1		18*7-8/4.3R-8, Without Trace
2	3220-420001-10	Front Tires 前轮胎	1		200/50-10/6.50F-10, With Trace
2	3220-420001-30	Front Tires 前轮胎	1		200/50-10/6.50F-10, Without Trace

4000

Steering System

转向系统

0401 Rear Axle Steering Assembly

后桥转向总成

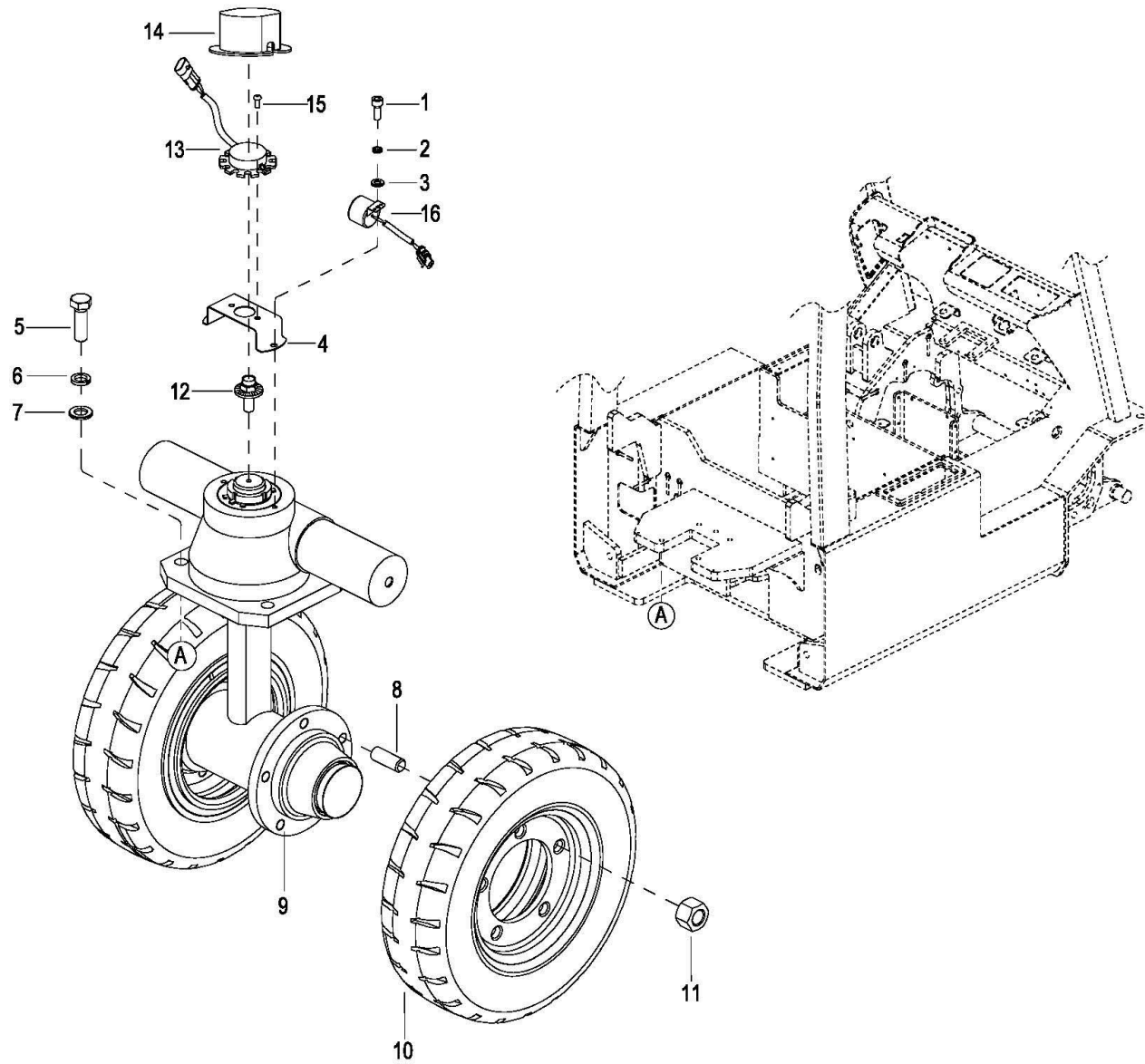

0401 Rear Axle Steering Assembly

后桥转向总成

Index 序号	Part No. 零件编号	Part Name 零件名称	No. 数量	Applied Date 适用日期	Remark 备注
1	302001000110	Screw M6x16 螺钉	2		
2	304000000050	Lockwasher Φ6 弹垫	2		
3	304000000036	Flatwasher Φ6 平垫	2		
4	3218-500001-0A	Potentiometer Holder 电位器支架	1		
5	301000000005	Bolt M16x50 螺栓	5		
6	304003000009	Lockwasher Φ16 弹垫	5		
7	304000000044	Flatwasher Φ16 平垫	5		
8	3218-500004-00	Stud 后轮螺柱	10		
9	3218-520000-10	Steering Axle 转向桥	1		See 0402
10	3218-510000-00	Back Tires Assembly 后轮胎总成	2		See 0403, With Trace
10	3218-510000-30	Back Tires Assembly 后轮胎总成	2		See 0403, Without Trace
11	3218-500003-00	Nut 后轮球型螺母	10		
12	3218-900002-00	Copper bolt 铜螺栓	1		
13	3625-600003-00	Potentiometer 角度电位器	1		
14	3218-500006-00	Shield Rubber 电位器护罩	1		
15	202800700004	Screw M4x8 螺钉	2		
16	3218-600700-00	Alarm Buzzer 蜂鸣器	1		

0402 Steering Axle

转向桥

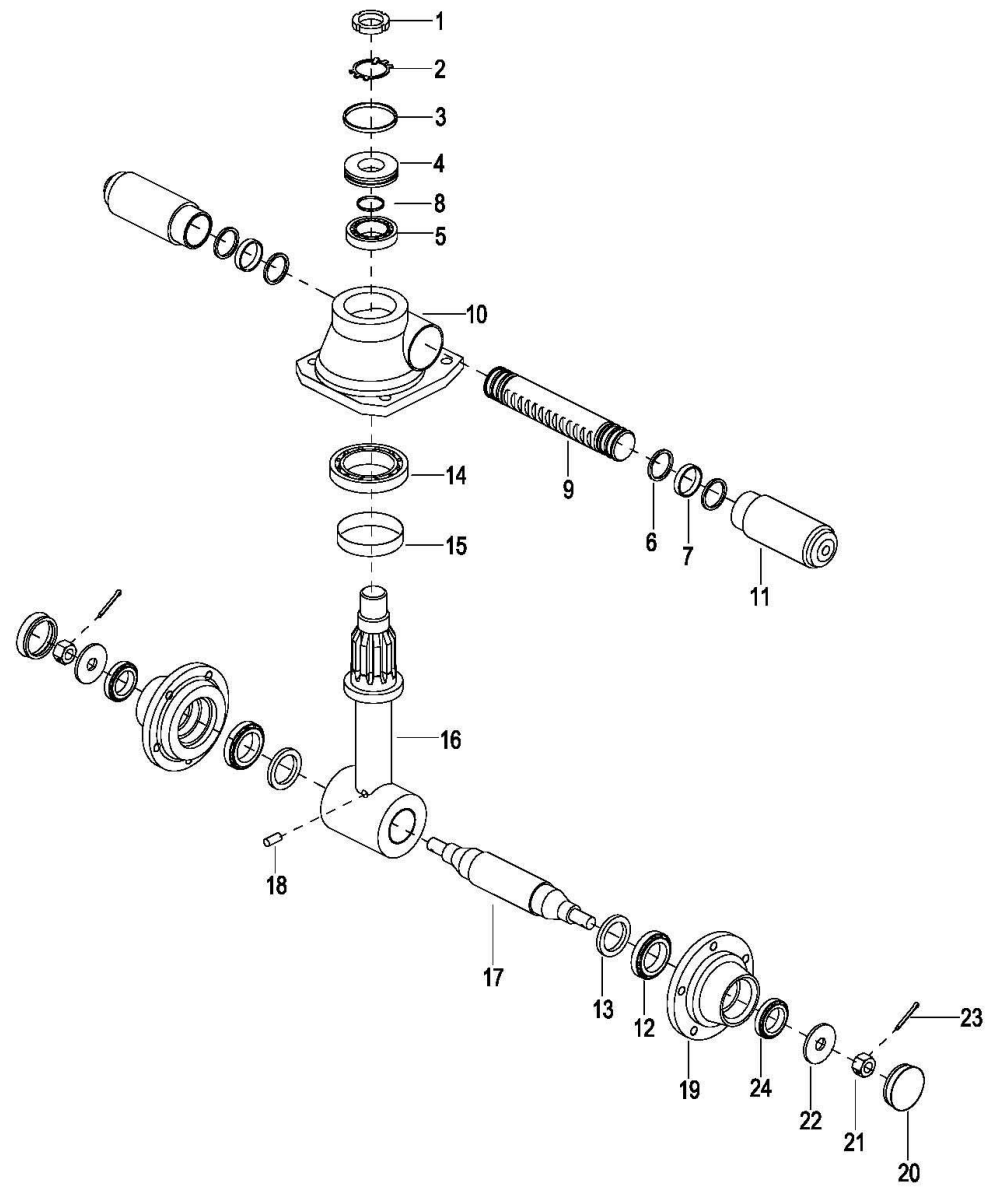

0402 Steering Axle

转向桥

Index 序号	Part No. 零件编号	Part Name 零件名称	No. 数量	Applied Date 适用日期	Remark 备注
1	3218-520001-00	Nut M39x1.5 螺母	1		
2	3218-520002-00	ThrustWasher 止推垫片	1		
3	3218-520003-00	O-Ring D82x2.65 O型圈	1		
4	3218-520004-00	Bushing 衬套	1		
5	3218-520005-00	Bearing 32010 轴承	1		
6	3218-520006-00	U- Ring 40x50x6 U形密封圈	4		
7	3218-520007-00	Ring 45x50x12 支撑环	2		
8	3218-520029-00	O-Ring O形圈	1		
9	3218-520009-00	Cylinder Shaft 活塞杆体	1		
10	3218-520010-00	Rotary Bearings 回转支座	1		
11	3218-520011-00	Cylinder 缸筒	2		
12	3218-520026-00	Bearing 30208 轴承	2		
13	3218-520027-00	Seal 65x90x12 密封圈	2		
14	3218-520014-00	Bearing 32015 轴承	1		
15	3218-520015-00	Steal 90x115x12 密封圈	1		
16	3218-520016-00	Gear Axle 支撑齿轴	1		
17	3218-520017-00	Shaft 转向轮轴	1		
18	3218-520018-00	Pin A10x24 销	1		
19	3218-520025-00	Hub 轮毂	2		
20	3218-520020-00	Cover 轮毂盖	2		
21	3218-520021-00	Nut M24x2 螺母	2		
22	3218-520022-00	Washer 24 垫圈	2		
23	3218-520023-00	Pin 5x45 开口销	2		
24	3218-520024-00	Bearing 30206 轴承	2		

0403 Steering Wheel

转向轮

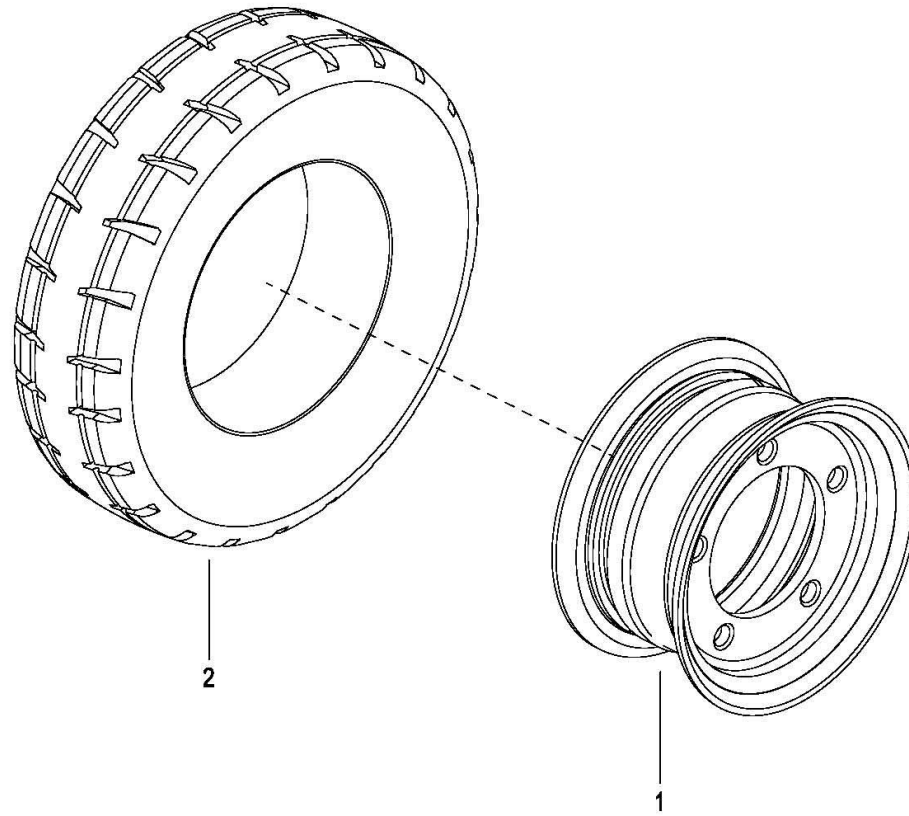

0403 Steering Wheel

转向轮

Index 序号	Part No. 零件编号	Part Name 零件名称	No. 数量	Applied Date 适用日期	Remark 备注
1	3218-511000-00	Rim Set 轮辋体	1		
2	3218-510001-00	Back Tires 后轮胎15X4.5-8	1		With Trace
2	3218-510001-20	Back Tires 后轮胎15X4.5-8	1		Without Trace

5000
Electrical System
电气系统

0501 Electrical Components
 电器元件

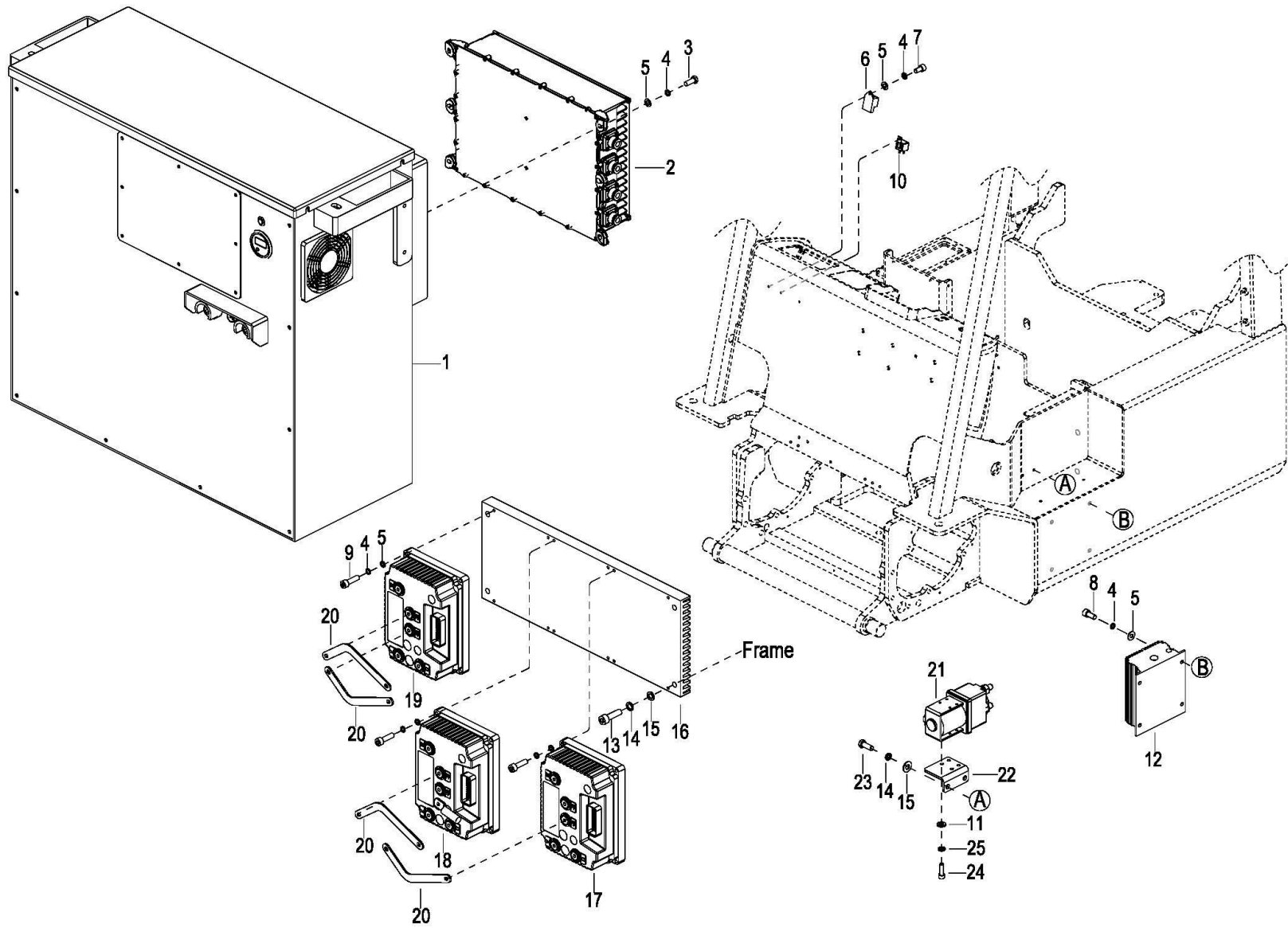

0501 Electrical Components

电器元件

Index 序号	Part No. 零件编号	Part Name 零件名称	No. 数量	Applied Date 适用日期	Remark 备注
1	LB89-00000Z-02	Lithium Battery 锂电池	1		80V205Ah
1	LB89-00000Z-03	Lithium Battery 锂电池	1		80V205Ah, With Remote Diagnostic Client
2	3127-670001-14-00	Charger 80V35A 充电机	1		For Industrial Three Core Plug
2	3127-670001-14-01	Charger 80V35A 充电机	1		For Europe
2	3127-670001-14-05	Charger 80V35A 充电机	1		For USA
2	3127-670001-14-07	Charger 80V35A 充电机	1		For China
3	301002000003	Bolt M6x12 螺栓	6		
4	304000000050	Lockwasher Φ6 弹垫	23		
5	304000000036	Flatwasher Φ6 平垫	23		
6	3218-600600-10	Flasher 闪光器	1		
7	302001000107	Screw M6x12 螺钉	1		
8	302001000110	Screw M6x16 螺钉	4		
9	302000000446	Screw M6x25 螺钉	12		
10	3525-684000-00	Light Relay 大灯继电器	1		
11	304000000038	Flatwasher ø4 平垫	4		
12	3530-642000-00	DCDC Converter DCDC 转换器	1		
13	302000000301	Screw M8x35 螺钉	4		
14	304000000052	Lockwasher Φ8 弹垫	4		
15	304000000040	Flatwasher Φ8 平垫	4		
16	3214-630001-00	Plate 控制器铝板	1		
17	3218-600100-32-00	Traction Motor Controller L 控制器	1		
18	3218-600100-32-10	Pump Motor Controller 控制器	1		
19	3218-600100-32-20	Traction Motor Controller R 控制器	1		For CPD15TVL
19	3218-600100-32-30	Traction Motor Controller R 控制器	1		For CPD18/20TVL

20		3231-630003-00	Copper Bar	铜条	4		
21		3218-634000-10	Contactora	接触器	1		
22		4103-610001-00	Contactora Plate	接触器安装板	1		
23		301002000013	Bolt M8x16	螺栓	2		
24		302001000006	Screw M4x10	螺钉	4		
25		304000000048	Lockwasher ø4	弹垫	4		

0502 Wiring Harness Assembly

线束总成

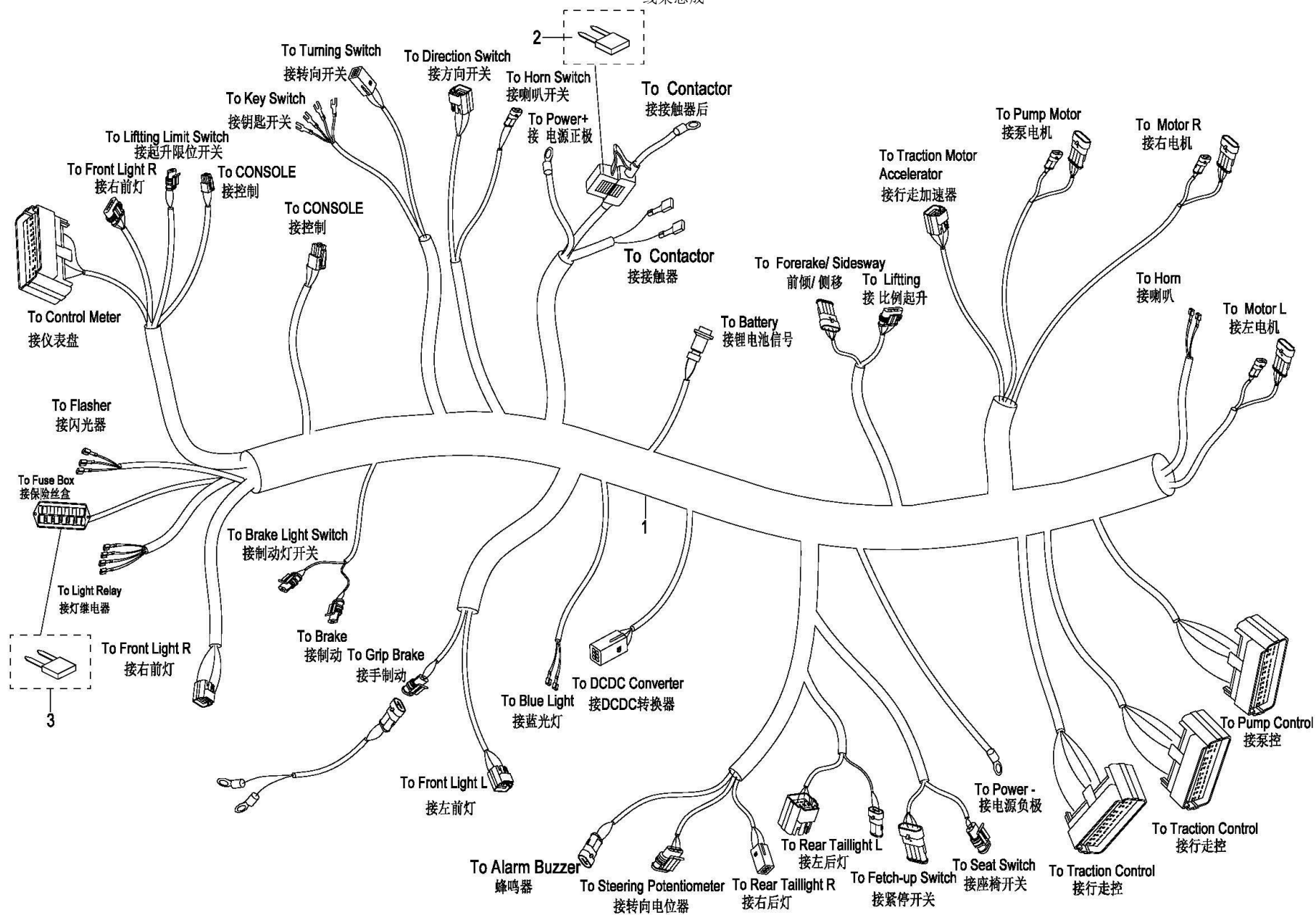

0502 Wiring Harness Assembly

线束总成

Index 序号	Part No. 零件编号	Part Name 零件名称	No. 数量	Applied Date 适用日期	Remark 备注
1	3214-621000-10	Main Harness 主线束	1		
2	1113-520025-00	Fuse 5A 保险丝	1		
3	1115-540001-00	Fuse 10A 保险丝	4		

0503 Cable Assembly
电缆总成

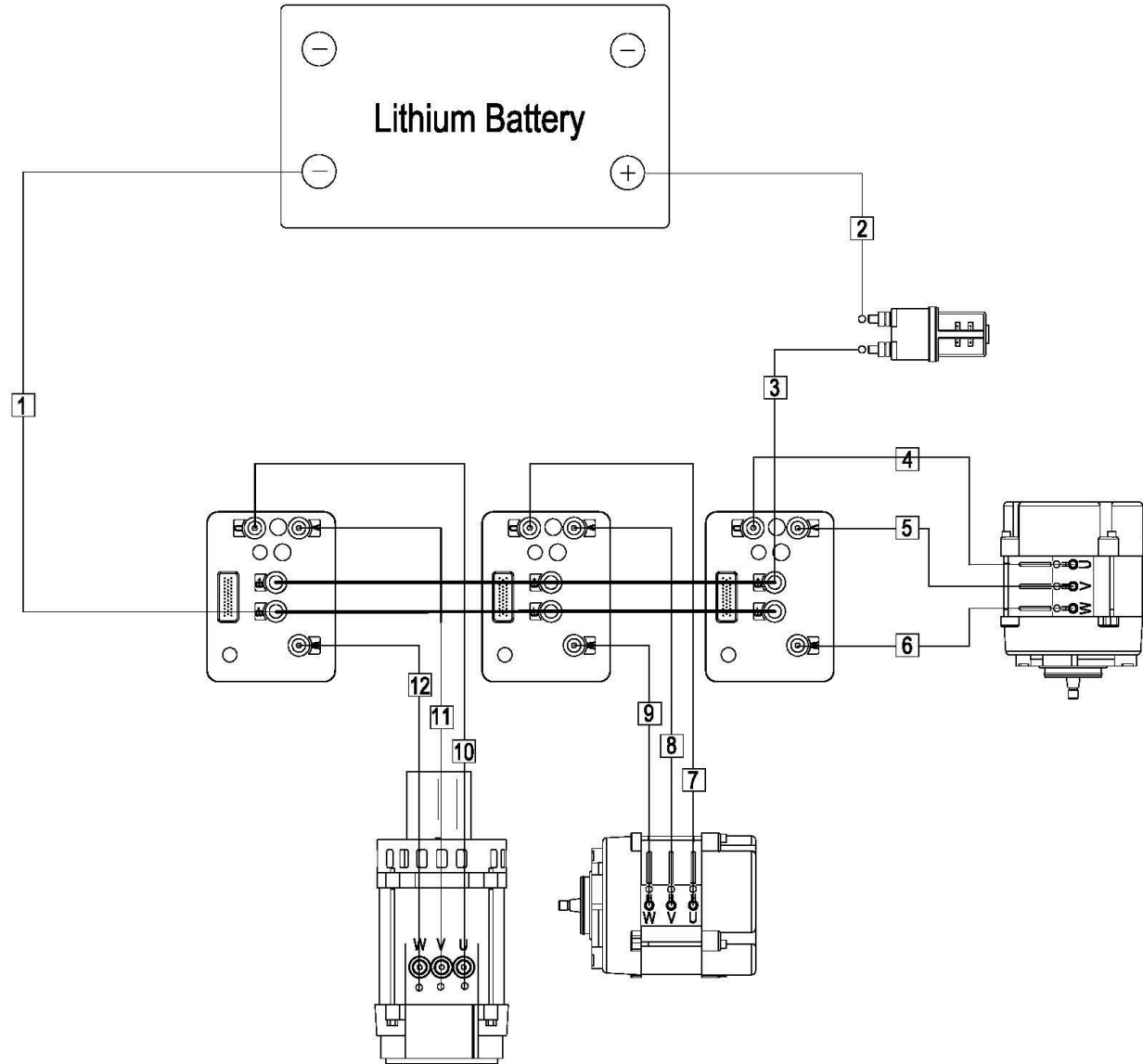

0503 Cable Assembly

电缆总成

Index 序号	Part No. 零件编号	Part Name 零件名称	No. 数量	Applied Date 适用日期	Remark 备注
1	3214-610012-00	Battery - to Controller 电瓶负极到控制器	1		
2	3214-610011-00	Battery + to Contactor 电瓶正极到接触器	1		
3	3214-610010-00	Contactor to Controller 接触器正极到控制器	1		
4	3214-610001-00	L-Drive Motor cable U LU 电缆	1		
5	3214-610002-00	L-Drive Motor cable V LV 电缆	1		
6	3214-610003-00	L-Drive Motor cable W LW 电缆	1		
7	3214-610004-00	R-Drive Motor cable U RU 电缆	1		
8	3214-610005-00	R-Drive Motor cable V RV 电缆	1		
9	3214-610006-00	R-Drive Motor cable W RW 电缆	1		
10	3214-610007-00	Pump Motor cable U PU 电缆	1		
11	3214-610008-00	Pump Motor cable V PV 电缆	1		
12	3214-610009-00	Pump Motor cable W PW 电缆	1		

0504 Lithium Battery Assembly

锂电池总成

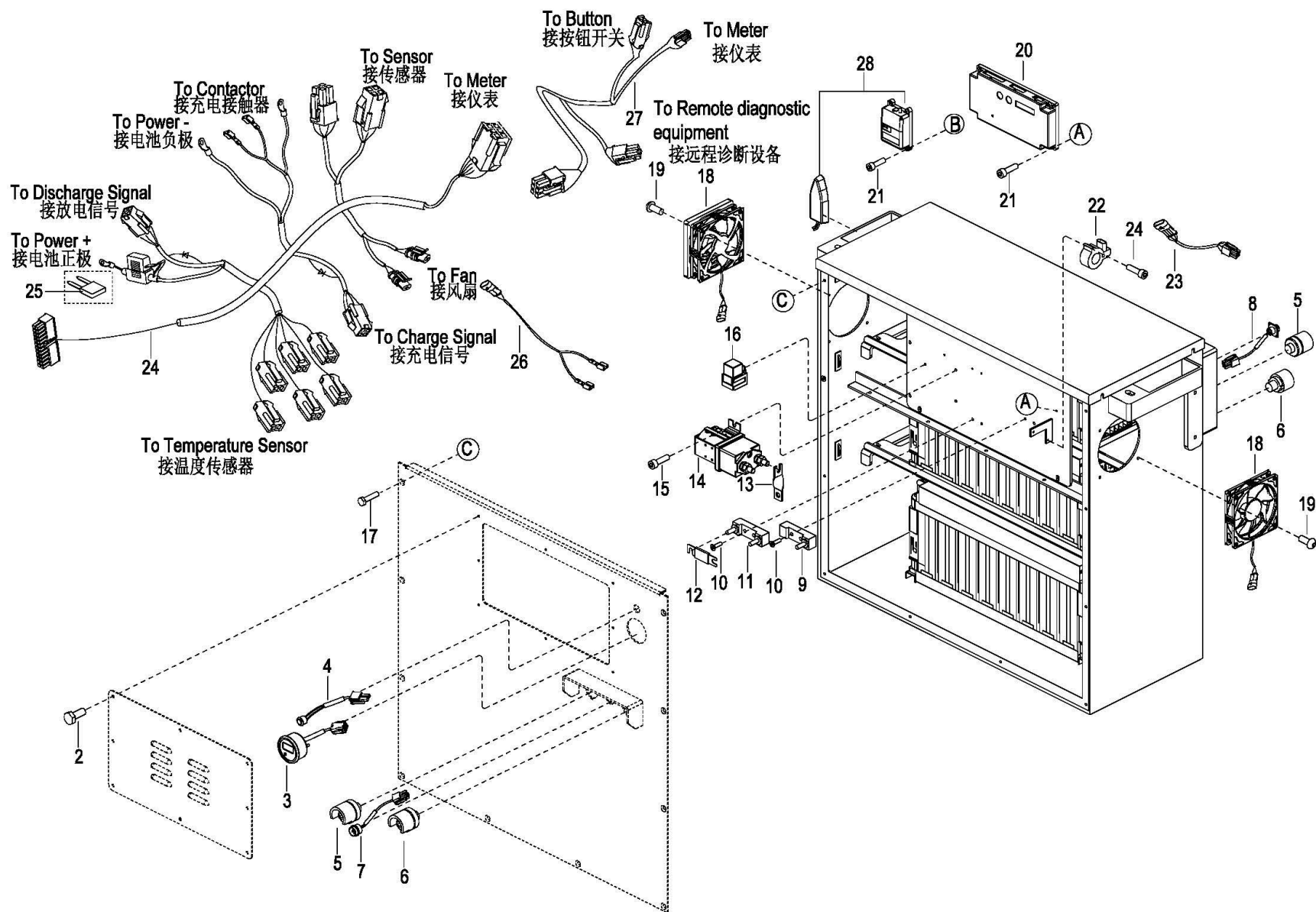

0504 Lithium Battery Assembly

锂电池总成

Index 序号	Part No. 零件编号	Part Name 零件名称	No. 数量	Applied Date 适用日期	Remark 备注
2	301016000006	Bolt M5x12 螺栓	8		
3	LB00-200011-00	Electricity meter 圆形显示仪表	1		
4	LB11-400020-0A	Button harness 按钮线束	1		
5	LB00-200232-00	Terminal Black 接线柱黑	2		
6	LB00-200231-00	Terminal Red 接线柱红	2		
7	LB06-400012-1D	Communication line 内部通讯线	1		
8	LB30-400009-1F	Charge Communication line 内部充电通讯连接线	1		
9	LB00-200058-00	Base 单柱头底座	1		
10	302003000004	Screw M6x16 螺钉	4		
11	3112-600400-00	Fuse Base 保险丝座	1		
12	LB00-200157-00	Fuse 500A 保险丝	1		
13	LB11-400012-0A	Copper 接触器铜条	1		
14	LB00-200005-00	Contactora 48V 接触器	1		
15	202800000001	Screw M6x12 组合螺钉	2		
16	3525-684000-10	Relay 继电器	1		
17	302000000062	Screw M6x10 螺钉	10		
18	LB11-400040-00	Fan 风扇线束	2		
19	302000000502	Screw ST4.8x19 螺钉	8		
20	LB00-200043-00	Plate Assembly 保护板总成	1		
21	202800000005	Screw M4x16 组合螺钉	4		
22	LB00-200042-00	Sensor 进口霍尔传感器	1		
23	LB23-400014-0A	Sensor Wire 双路霍尔传感器线束	1		
24	LB30-400008-1H	Main Harness 主线束	1		
25	LB00-200235-00	Fuse 15A 保险丝	1		
26	LB78-400057-00	Fan Control Wire 风扇控制线	1		

27		LB23-400020-00	Button Harness 远程仪表按钮延长线	1		
28		LB00-200238-00	Remote diagnostic client 远程客户端	1		Option, For China
28		LB00-200262-00	Remote diagnostic client 远程客户端	1		Option, For Overseas

6000

Hydraulic System

液压系统

0601 Hydraulic System I
 液压管路 I

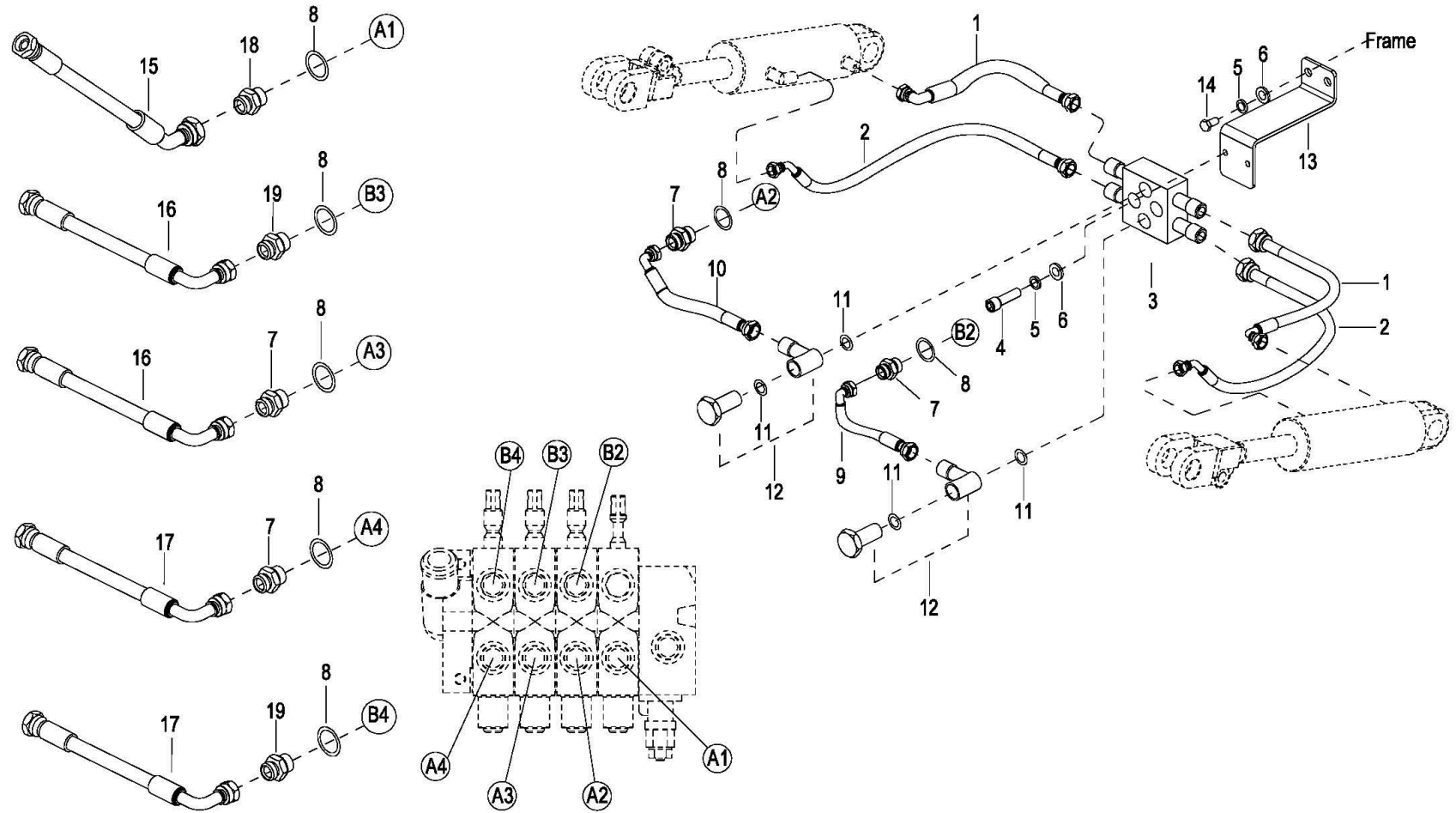

0601 Hydraulic System I

液压管路 I

Index 序号	Part No. 零件编号	Part Name 零件名称	No. 数量	Applied Date 适用日期	Remark 备注
1	3214-716000-00	Forward Hose 油缸前倾油管	2		
2	3214-718000-00	Backward Hose 油缸后倾油管	2		
3	3218-750000-A0	Three-way Valve 倾斜三通	1		
4	302000000299	Screw M8x20 螺钉	2		
5	304000000052	Lockwasher Φ8 弹垫	2		
6	304000000040	Flatwasher Φ8 平垫	2		
7	2701-201600-00	Connector M20x1.5-M16x1.5 直通接头	7		
8	306002000021	O-Ring 17x2.65 O 形圈	7		
9	3214-713000-00	Hose, ValveA2 to 3-way 多路阀 A2到倾斜三通	1		
10	3214-714000-00	Hose, ValveB2 to Three-way 多路阀 B2到倾斜三通	1		
11	306001000001	Washer ø14 组合垫圈	4		
12	2707-141400-00	Joint 铰接接头	2		
13	3214-100005-00	Three-way Valve Plate 三通安装板	1		
14	301002000013	Bolt M8x16 螺栓	2		
15	3214-731000-00	Lifting Hose Assembly 起升油管	1		
16	3214-732000-00	Sideshifter Hose 侧移	2		
17	3214-734000-00	Adjustable Hose 可调油管	2		
18	2701-202000-00	Connector M20x1.5-M20x1.5 直通接头	1		
19	2701-201600-10	Connector M20x1.5-M16x1.5 直通长接头	2		

0602 Hydraulic System II

液压管路II

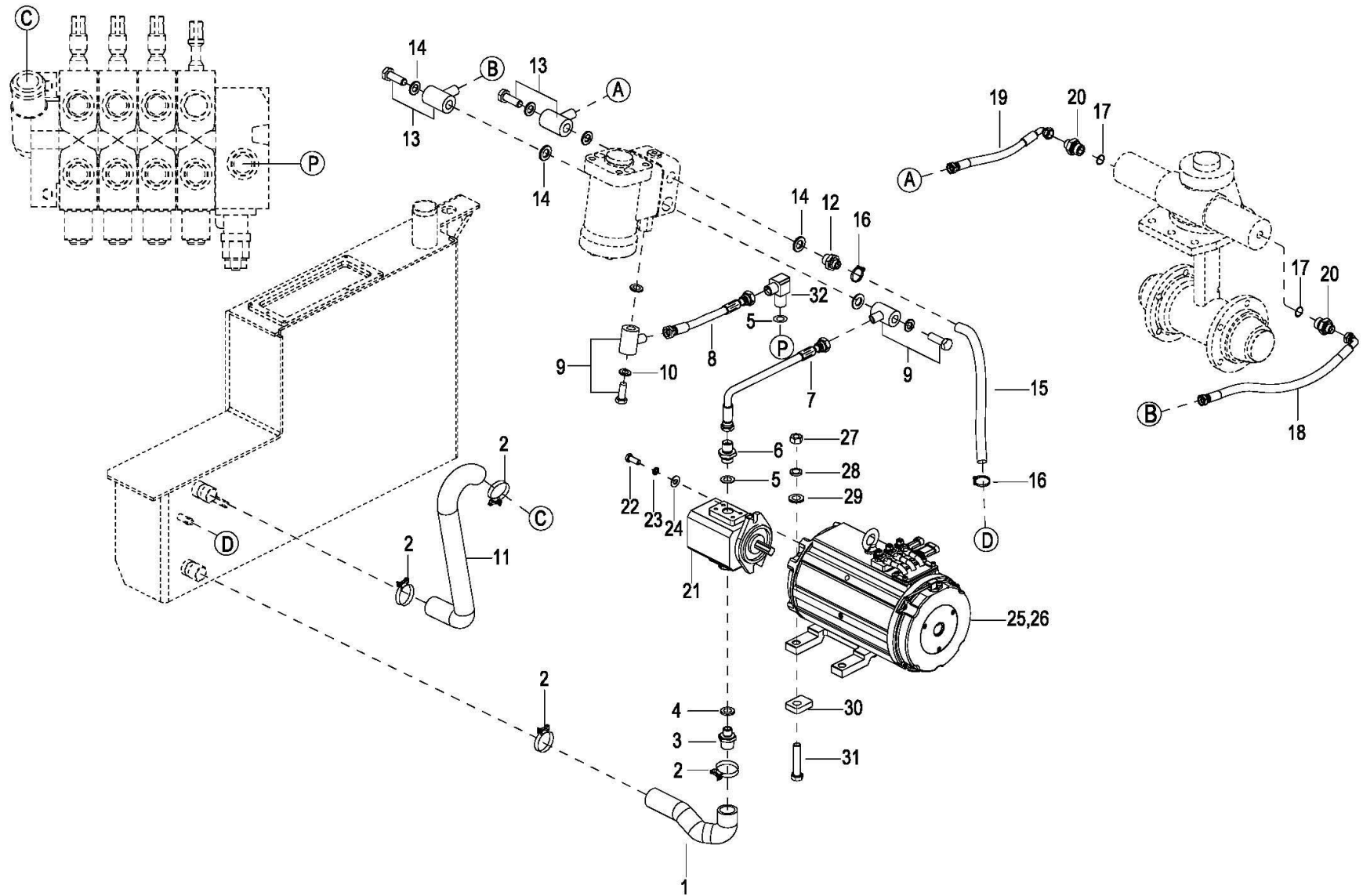

0602 Hydraulic System II

液压管路II

Index 序号	Part No. 零件编号	Part Name 零件名称	No. 数量	Applied Date 适用日期	Remark 备注
1	3214-700005-00	Oil suction pipe 吸油管	1		
2	202800000187	Clip Φ 32-50 卡箍	6		
3	2713-243200-00	Connector M24 \times 1.5- Φ 32 直通接头	1		
4	306002000022	O-Ring 21.2 \times 2.65 O 形圈	1		
5	306002000019	O-Ring 19 \times 2.65 O 形圈	2		
6	2701-222000-00	Connector M22 \times 1.5-M20 \times 1.5 直通接头	1		
7	3214-712000-00	Hose,Pump to Redirector 泵到转向器油管	1		
8	3214-715000-00	Hose,Redirector to Valve 转向器到多路阀	1		
9	2706-202000-00	Elbow M20 \times 1.5-M20 \times 1.5 过渡接头	2		
10	306001000004	Washer Φ 20 组合垫圈	4		
11	3214-700004-00	Hose,Ruturn 回油管	1		
12	2713-181300-00	Connector M18 \times 1.5- Φ 13 直通接头	1		
13	2706-181600-00	Elbow M18 \times 1.5-M16 \times 1.5 铰接接头	2		
14	306001000003	Washer Φ 18 组合垫圈	5		
15	3715-720000-00	Redirector Ruturn Hose 转向器回油管	1		
16	0000-000468-00	Clip Φ 10-16 卡箍	2		
17	306001000001	Washer Φ 14 组合垫圈	2		
18	3216-721000-00	Hose-L,Redirector to Steering 转向器到转向桥左	1		
19	3216-722000-00	Hose-R,Redirector to Steering 转向器到转向桥右	1		
20	2702-141600-00	Connector G1/4-M16 \times 1.5 直通接头	2		
21	3115-750000-00-01	Gear Pump 齿轮泵	1		
22	301004000060	Bolt M10 \times 1.25 \times 30 螺栓	2		
23	304000000053	Lockwasher Φ 10 弹垫	2		
24	304002000006	Flatwasher Φ 10 平垫	2		

25		3214-660000-00	Lift Motor	提升电机	1		
26		3214-66001X-00	Encoder	编码器	1		
27		303001000007	Nut M12	螺母	4		
28		304000000051	Lockwasher Φ12	弹垫	4		
29		304000000041	Flatwasher Φ12	平垫	4		
30		3218-600006-00	Shock Absorber	橡胶垫	4		
31		301000000269	Bolt M12x50	螺栓	4		
32		2701-222090-00	Joint M22×1.5-M20×1.5	直角接头	1		

0603 Oil Tank
油箱

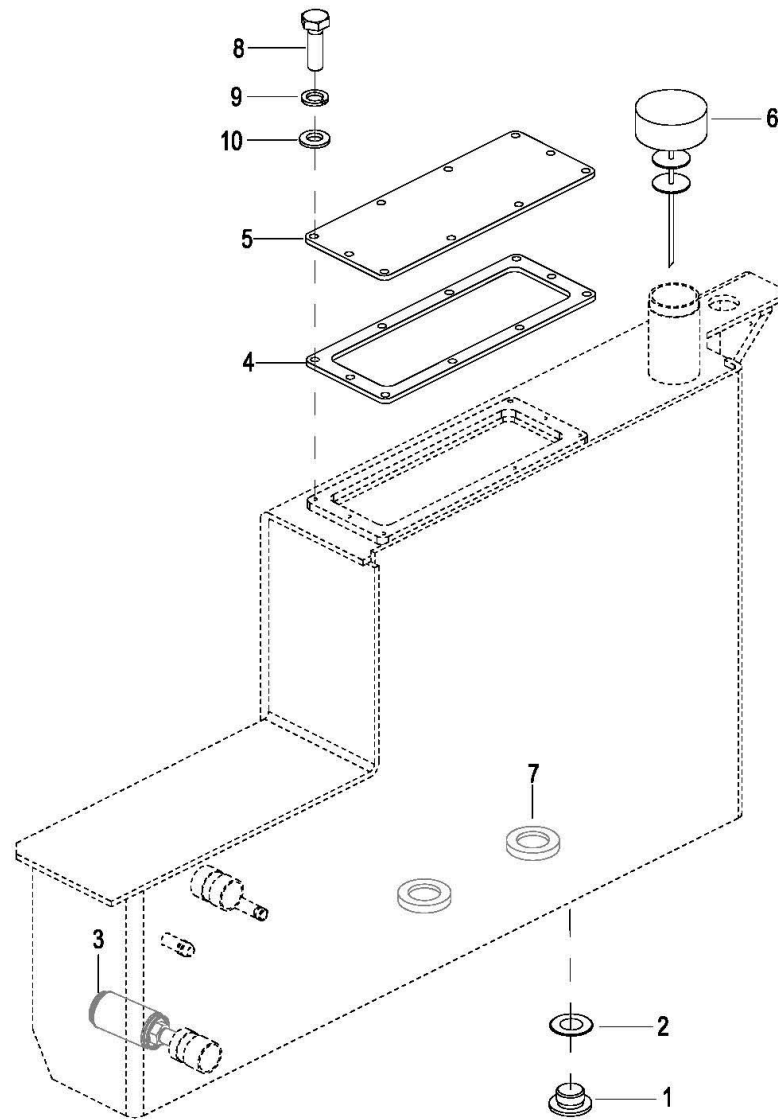

0603 Oil Tank

油箱

Index 序号	Part No. 零件编号	Part Name 零件名称	No. 数量	Applied Date 适用日期	Remark 备注
1	3218-110001-00	Plug Drain M18x1.5 放油螺塞	1		
2	306001000003	Washer Φ18 组合垫圈	1		
3	3218-110008-00	Filter 虑油器	1		
4	3218-112001-00	Gasket 密封垫	1		
5	3214-131001-00	Oil Tank Cover 油箱盖	1		
6	7331-710007-00	Cap 加油盖	1		
7	3218-110010-00	Magnet 磁铁	2		
8	301000000090	Bolt M6x16 螺栓	10		
9	304000000050	Lockwasher Φ6 弹垫	10		
10	304000000036	Flatwasher Φ6 平垫	10		

9000
Addendum
附录

0901 Label

标贴

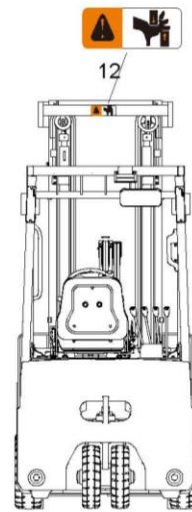
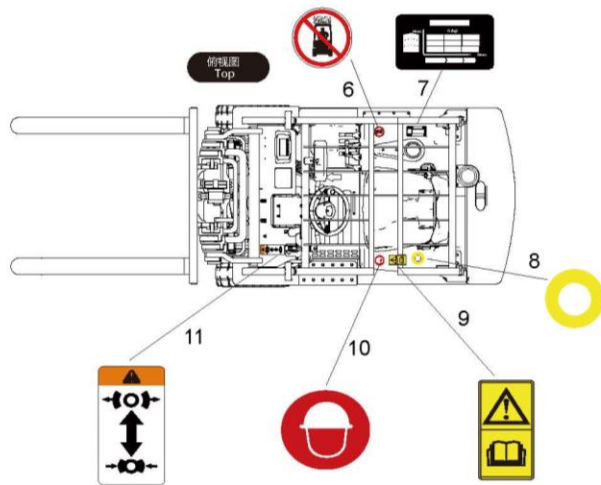
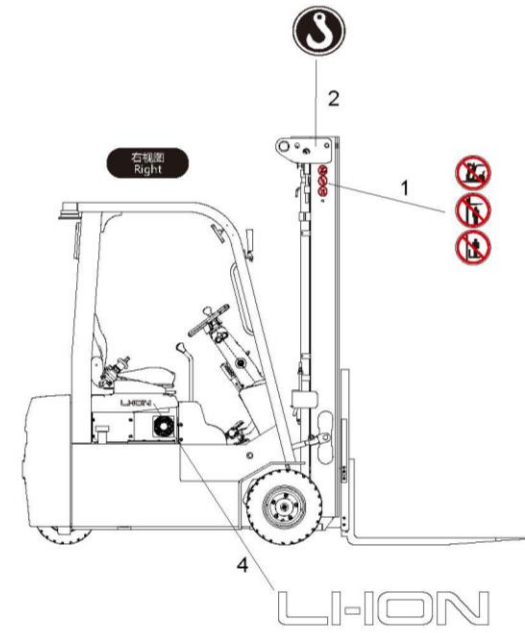
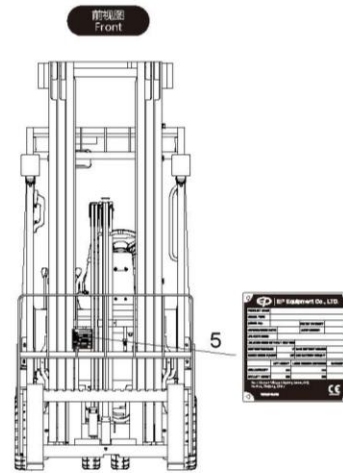
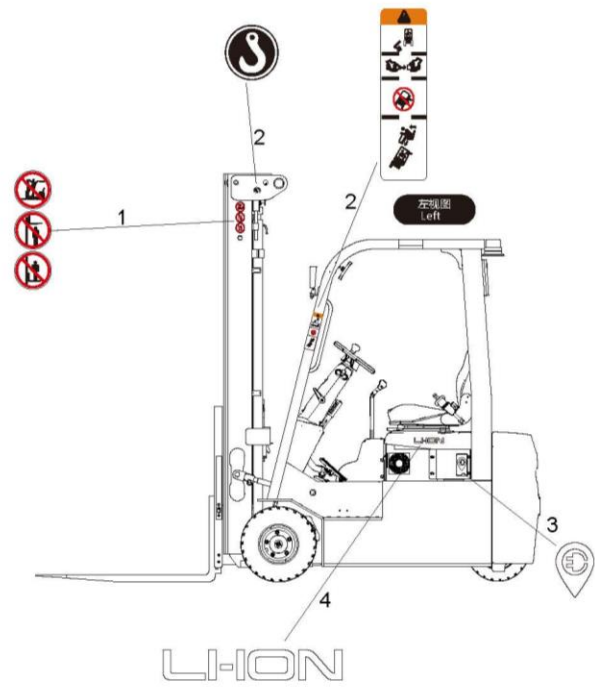

0901 Label

标贴

Index	Part No.	Part Name	No.	Applied Date	Remark
1	508000000083	Mast Safety Label 叉车门架安全标贴	2		
2	508000002086	Forklift Label 叉车整版标贴	1		
3	508000000124	Charge Label 充电指示标贴	1		
4	508000001997	Lithium battery Label 锂电池标贴	2		
5	508000001578	Nameplate 铭牌	1		With EP, Chinese
5	508000001579	Nameplate 铭牌	1		Without EP, Chinese
5	508000001580	Nameplate 铭牌	1		With EP, English
5	508000001581	Nameplate 铭牌	1		Without EP, English
6	508000000061	Rainy Label 雨天禁用标贴	1		
7	508000001895	Load Nameplate 不锈钢载荷铭牌	1		
8	508000002341	Emergency Stop Switch 急停开关标贴	1		
9	508000000103	Manual Label 翻阅手册标贴	1		
10	508000000069	Hard Hat Label 安全帽标贴	1		
11	508000000067	Handbrake Label 手刹标贴	1		
12	508000000039	Hand Clip Label 夹手标贴	1		
13	508000005092	Watertight warning Label 防水警示标贴	1		